



Bendix™ VORAD® VS-400 Radar System

Troubleshooting Guide

Bendix™ VORAD® Collision Warning System
Bendix™ SmartCruise® Adaptive Cruise Control
Bendix™ BlindSpotter® Side Object Detection
BW2771 (Formerly VOTS0100)

June 2012

Warnings & Cautions	2
Recommended Tools	3
Before You Begin	4
Diagnostic Software and J1939 Diagnostics	4
Additional Warnings	4
Definitions	5
Forward Looking Radar (FLR)	5
Collision Warning System (CWS)	5
SmartCruise	5
Side Object Detection (SOD)	5
J1939 (CAN) Data Link	5
VS-400 Pretest Procedures	6
Power-Up Pretest	6
Retrieving Diagnostic Trouble Codes (DTCs)	7
Electrical Pretest	8
VS-400 Diagnostic Trouble Code (DTC) Isolation Procedures	22
Component Code: 13 - DIU Component Diagnostic Trouble Code (DTC)	22
Component Code: 14 - FLR Component Diagnostic Trouble Code (DTC)	23
Component Code: 25 - SmartCruise Configuration Error	24
Component Code: 32 - DIU J1939 Message Error	25
Component Code: 33 - FLR J1939 Message Error	26
Component Code: 35, 36 - J1939 Data Link Diagnostic Trouble Code (DTC)	27
Component Code: 39 - FLR Supply Voltage Out of Range	28
Component Code: 41, 42 - Driver Interface Unit External Speaker Diagnostic Trouble Code (DTC)	29
Component Code: 91 - Forward Looking Radar Out of Alignment	31
Component Code: 92 - Forward Looking Radar Not Detecting Objects or Radar Blocked	32
Component Code: 95 - Forward Looking Radar Ambient Temperature Out of Range	33
Side Object Detection (SOD)	34
System Operation	34
Diagnostic Trouble Code (DTC) Isolation Procedures	36
Appendix	37
1. Forward Looking Radar Alignment	37
2. Vertical Alignment	37
3. Horizontal Alignment	38
4. Component Power Supply Test	43
5. Wiring Diagrams: Collision Warning System with Side Object Detection	46
6. Connector Pin Descriptions	47
A. Forward Looking Radar	47
B. Driver Interface Unit	47
C. Side Sensor Display Unit	48
D. Side Sensor	48
7. Extracting VORAD Data	49-50
8. Vendor Contact Information	51

Warnings and Cautions



Improper use of this system could lead to a serious accident. Read this entire Driver Instructions document before operating the Bendix™ VORAD® VS-400 Forward Collision Warning System (CWS), Bendix™ SmartCruise® Adaptive Cruise Control System, or Bendix™ BlindSpotter Side Object Detection System. Pay particular attention to the safety messages below. This manual should be used in conjunction with proper training.

Limitations of the Bendix™ VORAD® VS-400 Collision Warning System

The Bendix™ VORAD® VS-400 Forward CWS, Bendix™ SmartCruise® Adaptive Cruise Control System, and Bendix™ BlindSpotter® Side Object Detection is intended solely as an aid for an alert and conscientious professional driver. It is not to be used or relied upon to operate a vehicle. The system should be used in conjunction with rear view mirrors and other instrumentation to maintain safe operation of the vehicle, ground personnel, and adjacent property. A vehicle equipped with the Bendix™ VORAD® VS-400 Forward Collision Warning System should be operated in the same safe manner as if the system were not installed. The system is not a substitute for normal safe driving procedures. It will not compensate for any driver impairment, such as drugs, alcohol, or fatigue. Should the system become inoperative, it could jeopardize the safety or lives of those who depend on the system for safety.



The system will not sense objects if the sensor view is obstructed. Therefore, do not place objects in front of the system sensor. Remove heavy buildups of mud, dirt, ice, and other materials.

Proper alignment is critical to correct operation of the system.

Testing and inspection of the system in accordance with these instructions and records of the results should be listed on the daily maintenance report. The units on operating vehicles must be tested each day (see the “Testing and Maintenance” section) prior to the vehicle’s operation. Results of this test must be recorded in the maintenance log.

People operating this equipment MUST check for proper operation at the beginning of every shift or safety inspection period.



People’s lives depend on the proper installation of this product in conformance with these instructions. It is necessary to read, understand, and follow all instructions shipped with the product.

Failure to follow all safety precautions and instructions may result in property damage, serious injury, or death.

The Bendix™ VORAD® VS-400 Forward Collision Warning System (CWS), Bendix™ SmartCruise® Adaptive Cruise Control System, or Bendix™ BlindSpotter Side Object Detection System is intended for commercial use. Proper installation of a backup aid requires a good understanding of truck electrical systems and procedures, along with proficiency in the installation.

Store these instructions in a safe place and refer to them when maintaining and/or reinstalling the product.

Recommended Tools

PC to Vehicle J1939 Link Adapter

- Nexiq P/N 125032 or Equivalent (J1939 compatible)

Digital Volt/Ohm Meter

- SPX/Kent-Moore P/N 5505027 or Equivalent

Test Lead Adapter Kit

- SPX/Kent-Moore P/N J-43318

Digital Level/Protractor

- Eaton P/N VV-KIT-03 or Equivalent

J1939 Data Link Tester

- Eaton P/N MF-KIT-04

Straight Edge Rule

- 4 to 6 Feet in Length

Other Product Literature (available at www.bendix.com)

- BW2772 – VS-400 Installation Guide
- BW2769 – VS-400 Driver Manual
- BW2798 – Side Object Detection Installation/Users Guide
- Service Bulletins

Before You Begin

The VORAD® VS-400 system is comprised of a Forward Looking Radar (FLR) unit and Driver Interface Unit (DIU) that utilizes the vehicle's J1939 data link to communicate with each other, as well as the vehicle's engine and/or chassis (cab) controller. It is recommended that the servicing technician be properly trained and familiar with the vehicle's electrical system, J1939 data link, and electronic components before attempting any of the troubleshooting procedures in this manual.

For information on training opportunities, along with up to date service bulletins and product literature, contact your local Bendix account manager or visit the Bendix website at www.bendix.com.

Additional Warnings

Some of the tests in this manual require the technician to use a test meter to measure the voltage and resistance of the vehicle's electrical circuits. If it becomes necessary to temporarily connect the test meter leads to wire harness terminals, it is recommended to use a test lead adapter kit (see recommended tools for P/N J-43318) or equivalent.

- Never insert test lead probes, nails, or paper clips into the vehicle harness connector terminals, as this can distort or damage the wire terminals.
- Never pierce wire insulation to test circuits, as this can result in damaged wires and wire corrosion.
- When making resistance checks on circuits, make sure the vehicle ignition is off to prevent damage to test equipment and vehicle components.

Definitions

Forward Looking Radar (FLR)

The VORAD® VS-400 Forward Looking Radar is a high frequency Doppler radar unit located on the front of the vehicle that transmits a focused beam of radio frequency (RF) energy ahead of the vehicle. Energy reflected off objects is reflected back to the FLR and processed by the unit's internal headway controller to determine the speed, distance, direction, and lane position of all detected objects.

Collision Warning System (CWS)

The headway controller within the FLR processes information about all objects detected by the radar and sends alert messages to the Driver Interface Unit (DIU) located in the dash via the vehicle's J1939 data link. The DIU uses a combination of visual and audible alerts to warn the driver of approaching hazards, or if following distances are too close for the current speed of the vehicle.

Bendix™ SmartCruise® (SC)

Bendix™ SmartCruise is a feature of the VS-400's Forward Looking Radar that controls the adaptive cruise control function of the engine. When enabled, SmartCruise will override the engine's set cruise speed in order to maintain a safe following distance when approaching slower moving traffic. The vehicle's engine must support and be enabled for adaptive cruise control in order for the VORAD® SmartCruise® function to operate. Contact your vehicle OEM for information on the engine's adaptive cruise control function.

Side Object Detection (SOD)

The VORAD Side Object Detection (SOD) is a stand-alone system that utilizes a close proximity pulse radar sensor to detect the presence of a vehicle in a lane adjacent to the host vehicle. The SOD includes its own Driver Display Unit (DDU) to report object detection and Diagnostic Trouble Code (DTC) information to the driver. The system may be installed separately, or as an option for the VS-400 system.

J1939 (CAN) Data Link

The J1939 data link is an SAE defined high-speed Controller Area Network (CAN) used to provide a means of communication between compliant electronic devices on the vehicle. The data link consists of a twisted pair of wires running within the vehicle's electrical harness that connects all J1939 compatible devices together in a chain.

Each end of the data link chain is terminated with a 120-ohm resistor to reduce electrical noise, or interference. The two terminating resistors also provide an easy means to test the integrity of the link by producing a combined 60-ohm link resistance that can be measured at any connection point on the link with a digital ohmmeter. Contact the vehicle OEM for information on the J1939 data link wiring and terminations.

VS-400 Pre-Test Procedures

Power-Up Pretest

Overview

This section shows the start up and system status display of the VORAD® VS-400 system's Driver Interface Unit.

Note: Refer to the Side Object Detection section for information on the operation and testing of the Side Object Detection system.

Power-up

With the vehicle's ignition turned to the ON position (Engine OFF), observe the power-up sequence of the VS-400 Driver Interface Unit (DIU).

If the DIU fails to power up, proceed to the Electrical Pretest procedure to check for power to the VS-400 system components.



VS-400 DIU Lamp Test at initial power-up

System Status

After about 30 seconds from when the ignition was powered on, the DIU should display the VORAD status screen. This screen will display which functions are enabled and if that function's operation is OK or Failed.

If a function has failed, the orange Diagnostic Trouble Code (DTC) lamp will be illuminated, indicating an Active code has been set. Proceed to the Retrieving Diagnostic Trouble Codes (DTCs) section.



VORAD status screen showing both Collision Warning System and Bendix SmartCruise® enabled but failed

Retrieving Diagnostic Trouble Codes (DTCs)

Overview

This section determines if the Driver Interface Unit (DIU) and the Forward Looking Radar (FLR) are both communicating on the vehicle's J1939 data link and if either component has set any Diagnostic Trouble Codes (DTCs). In order for the system to operate properly, the DIU and the FLR must be able to communicate with each other, as well as other ECU's on the vehicle's J1939 data link.

Note: This procedure requires an approved PR1210A communications adapter that supports J1939 communications.

Detecting Components

Connect the service PC to the vehicle's 9-pin J1939 diagnostic port connector with an approved RP1210A communications adapter. Start the diagnostic program and verify that a connection has been established with the vehicle's J1939 data link.

View the Vehicle Components screen and verify that the VORAD® VS-400 Forward Looking Radar (source address 42) and the Driver Interface Unit (source address 140) are being detected.

Data Link	Source Address	ECU Description
J1939	42	Forward Looking Radar
J1939	140	Driver Interface Unit

- If the DIU or the FLR are not being detected, proceed to the Electrical Pretest procedure to check for power to the VS-400 system components and that all components are properly connected to the vehicle's J1939 data link.

Viewing Diagnostic Trouble Codes (DTCs)

View the Vehicle Diagnostic Trouble Codes (DTCs) screen in the diagnostic software and verify if the Forward Looking Radar or the Driver Interface Unit have set any Active or Inactive codes.

- If an Active VS-400 code is present, record the vehicle Diagnostic Trouble Code (DTC) information and proceed to Diagnostic Procedure in this manual for the Active code for more information. Do not clear any codes at this time.
- If only Inactive (historic) VS-400 codes are present, record the vehicle Diagnostic Trouble Code (DTC) information and clear all historic Diagnostic Trouble Codes (DTCs). Road test the vehicle to verify proper operation of the VS-400 system.

Clearing Diagnostic Trouble Codes (DTCs)

After all repairs have been made and the system is functioning normally, clear all vehicle codes before placing the vehicle back into service. To clear codes, connect the service PC to the vehicle and start diagnostic software. View the Vehicle Diagnostic Trouble Codes (DTCs) screen and select Clear All. Refresh the screen to verify all historic codes have been cleared and that no Active codes are present.

Electrical Pretest

Overview

This test will verify that all electrical connections to the VORAD® VS-400 Forward Looking Radar (FLR) and the Driver Interface Unit (DIU) are correct for proper operation. This test should be performed before beginning any of the Diagnostic Trouble Code (DTC) isolation procedures.



Note: Refer to the Side Object Detection section for information on testing the Side Object Detection electrical connections.

- Never insert test lead probes, nails, or paper clips into the vehicle harness connector terminals, as this can distort or damage the wire terminals.
- Never pierce wire insulation to test circuits, as this can result in damaged wires and wire corrosion.
- When making resistance checks on circuits, make sure the vehicle ignition is off to prevent damage to test equipment and vehicle components.

Required Tools

1. Digital Volt / Ohm Meter

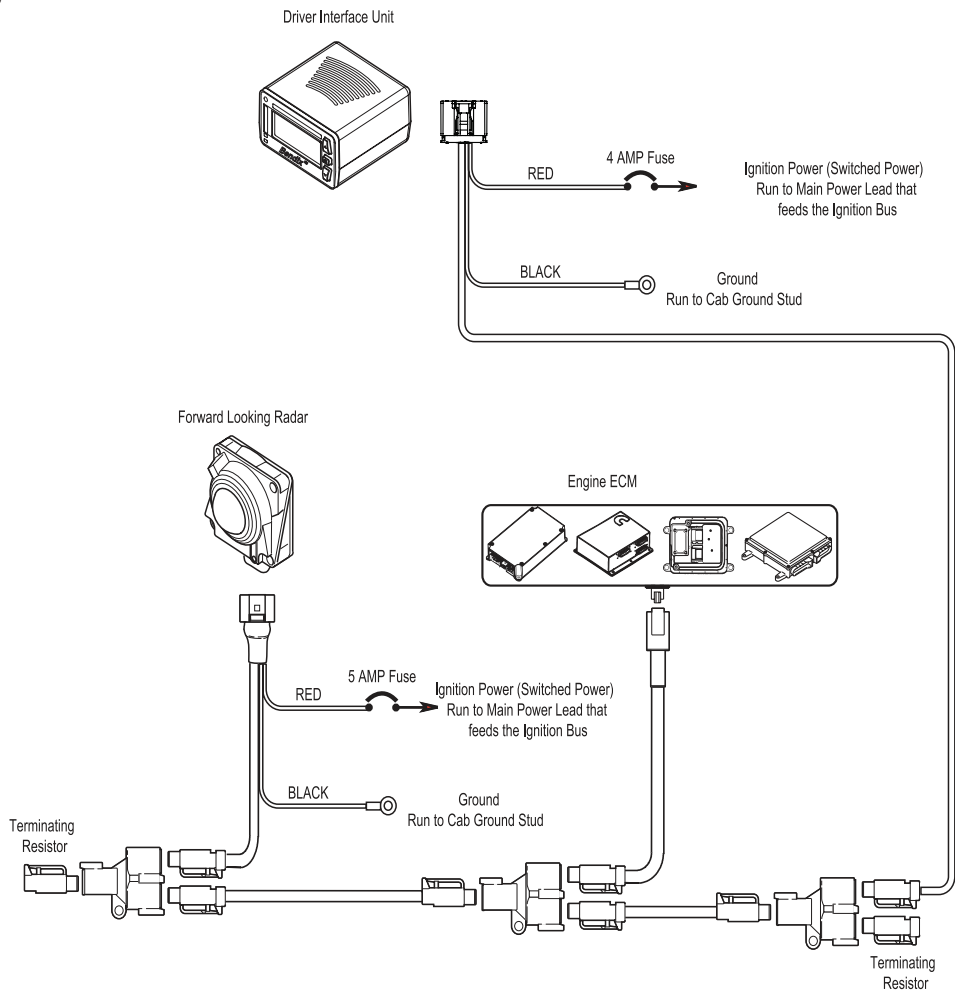

Pretest Procedures

Step	Procedure
A	<ol style="list-style-type: none">1. Vehicle Ignition: Key-ON, Engine-OFF.2. Measure and record the vehicle battery voltage at the battery terminals.<ol style="list-style-type: none">a. If the battery voltage measures within 2 volts of the battery-rated voltage. (10-12 volts for a 12-volt battery)<ol style="list-style-type: none">i. Proceed to Step Bb. If the battery voltage measures less than 2 volts of the battery-rated voltage. (less than 10 volts for a 12-volt battery)<ol style="list-style-type: none">i. Test Failed. Check batteries and charging system for proper operation, repair as required. Repeat Step.

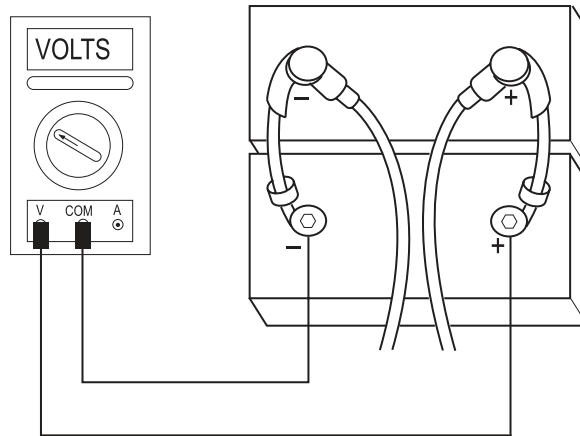

Pretest Procedures

Step	Procedure
B	<ol style="list-style-type: none"> 1. Vehicle Ignition: Key-OFF, Engine-OFF. 2. Disconnect the 8-way connector from the back of the VS-400 Driver Interface Unit (DIU). 3. Measure for zero voltage on pins 4 and 5 on the harness connector. <ol style="list-style-type: none"> a. If the voltage is 0.5 volts or less. <ol style="list-style-type: none"> i. Proceed to Step C. b. If the voltage is greater than 0.5 volts, but less than battery voltage. <ol style="list-style-type: none"> i. Test Failed. Check DIU power supply wiring for sources of stray voltage or shorts to voltage. c. If the voltage is within 0.6 volts of the battery voltage measured in Step A. <ol style="list-style-type: none"> i. Test Failed. The DIU is improperly wired to battery power. Correct the wiring by connecting the FLR to ignition power and repeat Step.

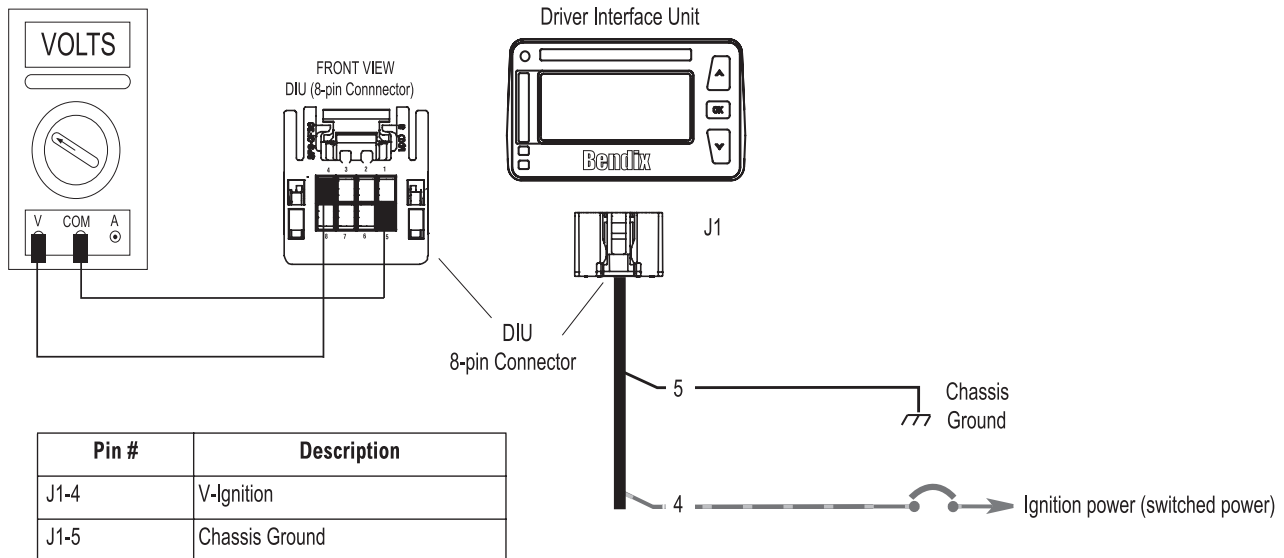

Step	Procedure
C	<ol style="list-style-type: none"> 1. Vehicle Ignition: Key-ON, Engine-OFF. 2. Measure for ignition voltage on pins 4 and 5 on the harness connector. <ol style="list-style-type: none"> a. If the voltage is within 0.6 volts of the battery voltage measured in Step A. <ol style="list-style-type: none"> i. Proceed to Step D. b. If the voltage is less than 0.6 volts of the battery voltage measured in Step A or open. <ol style="list-style-type: none"> i. Test Failed. Check component fuse. Troubleshoot power supply to the DIU for open/corroded connections or shorts to ground and repeat Step.

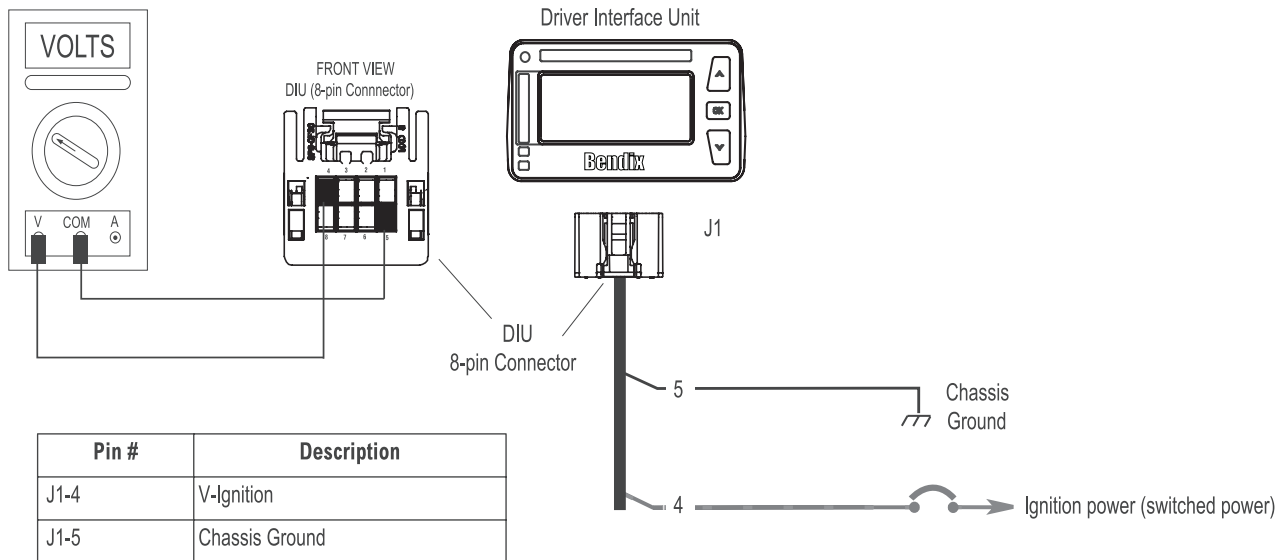

Pretest Procedures

Step	Procedure
D	<ol style="list-style-type: none"> 1. Vehicle Ignition: Key-ON, Engine-OFF. 2. Measure for J1939 data voltage on pins 7 and 5 of the DIU harness connector. (J1939 High to Ground) <ol style="list-style-type: none"> a. If the voltage is fluctuating between 2 to 5 volts. <ol style="list-style-type: none"> i. Proceed to Step E. b. If the voltage is a constant at 0 volts. <ol style="list-style-type: none"> i. Test Failed. Check for open/loose connections in the vehicle's J1939 data link harness. (See Note) <p>Note: Refer to vehicle OEM repair manual or contact the OEM for more information on the J1939 data link harness.</p>

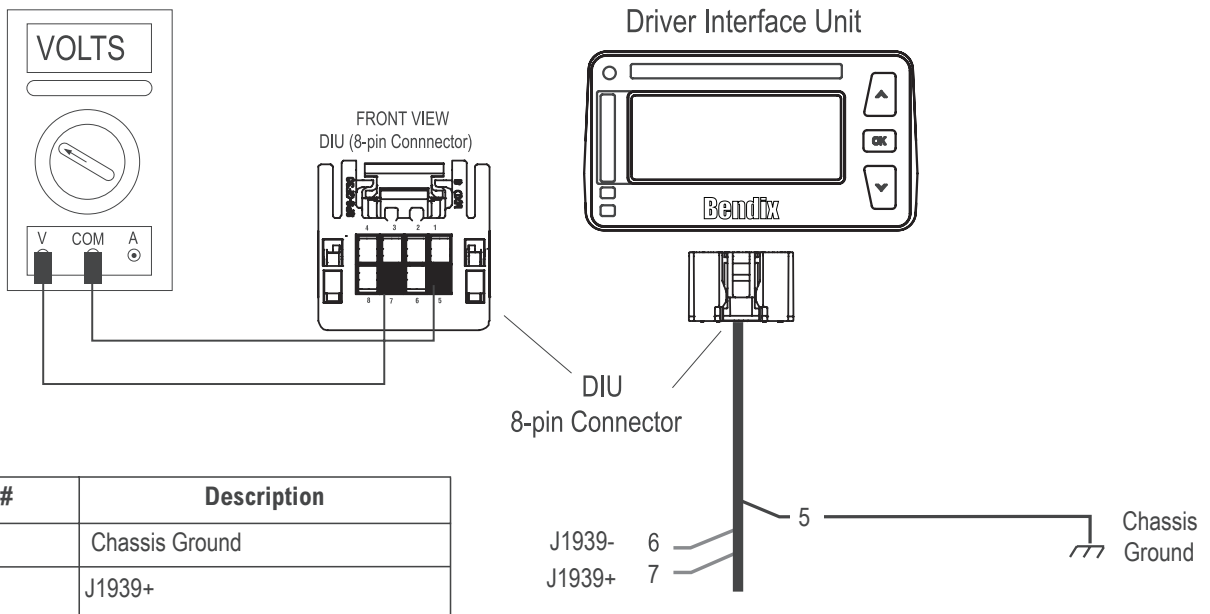

Pretest Procedures

Step	Procedure
E	<ol style="list-style-type: none"> 1. Vehicle Ignition: Key-ON, Engine-OFF. 2. Measure for J1939 data voltage on pins 6 and 5 of the DIU harness connector. (J1939 Low to Ground) <ol style="list-style-type: none"> a. If the voltage is fluctuating between 0 to 3 volts. <ol style="list-style-type: none"> i. Proceed to Step F. b. If the voltage is a constant at 0 volts. <ol style="list-style-type: none"> i. Test Failed. Check for open/loose connections in the vehicle's J1939 data link harness. (See Note) <p>Note: Refer to vehicle OEM repair manual or contact the OEM for more information on the J1939 data link harness.</p>

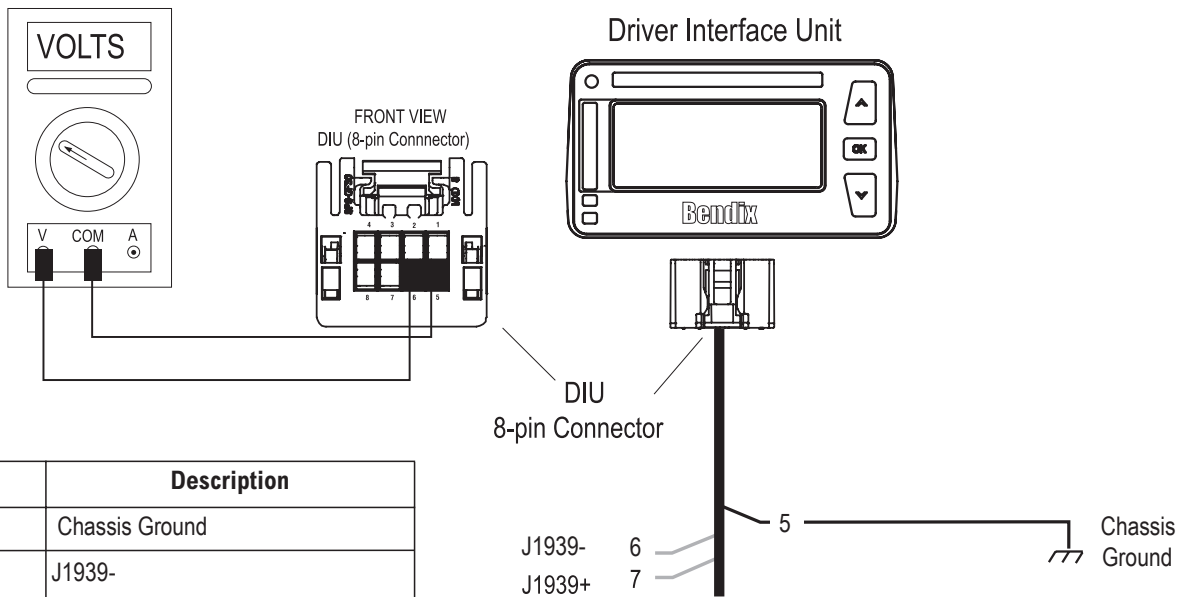

Pretest Procedures

Step	Procedure
F	<ol style="list-style-type: none"> 1. Vehicle Ignition: Key-OFF. 2. Measure for J1939 data link resistance across pins 7 and 6 of the DIU harness connector. (J1939 High to J1939 Low) <ol style="list-style-type: none"> a. If the resistance is between 57 and 63 ohms. <ol style="list-style-type: none"> i. Proceed to Step G. b. If the resistance is greater than 63 ohms or open (Infinite Resistance.) <ol style="list-style-type: none"> i. Test Failed. Check for missing J1939 data link terminating resistor(s) or open/loose connections in the vehicle's J1939 data link harness. (See Note) c. If the resistance is less than 57 ohms or near zero. <ol style="list-style-type: none"> i. Test Failed. Check for shorted connections in the vehicle's J1939 data link harness. Unplug all J1939 data link components from the data link to isolate a potential defective component. (See Note) <p>Note: Refer to vehicle OEM repair manual or contact the OEM for more information on the J1939 data link harness.</p>

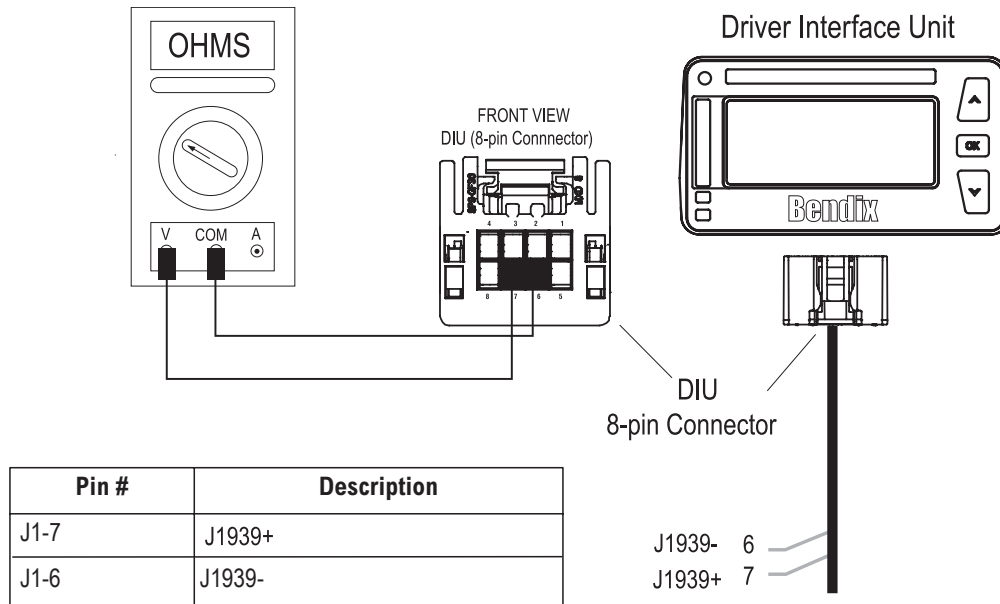

Pretest Procedures

Step	Procedure
G	<ol style="list-style-type: none"> 1. Vehicle Ignition: Key-OFF. 2. Measure the resistance across pins 7 and 5 (J1939 High to Ground.) 3. Measure the resistance across pins 6 and 5 (J1939 Low to Ground.) <ol style="list-style-type: none"> a. If both resistances are greater than 100K ohms or open (Infinite Resistance). <ol style="list-style-type: none"> i. Proceed to Step H. b. If either resistance is between 0 to 100K ohms. <ol style="list-style-type: none"> i. Test Failed. Check for shorted connections in the vehicle's J1939 data link harness. Unplug all J1939 data link components from the data link to isolate a potential defective component. (See Note) <p>Note: Refer to vehicle OEM repair manual or contact the OEM for more information on the J1939 data link harness.</p>

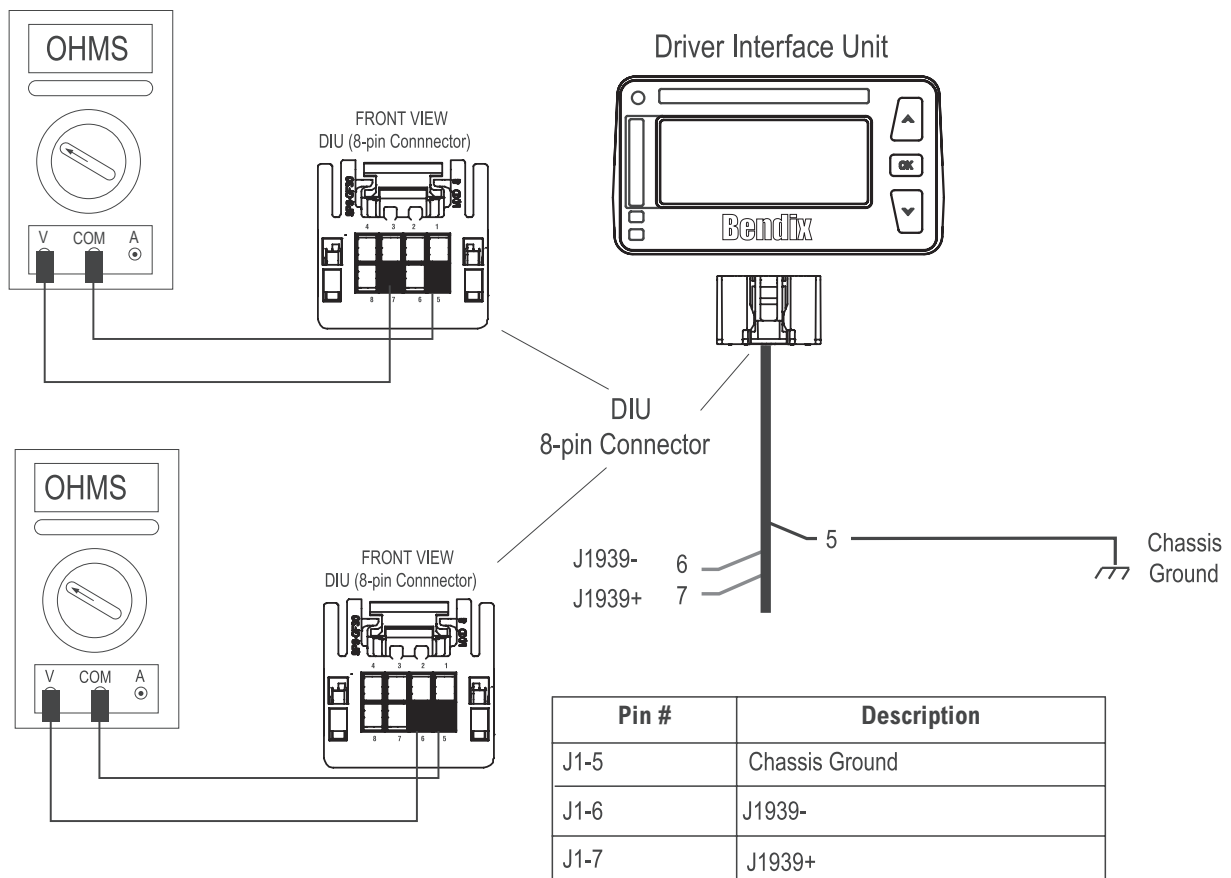

Pretest Procedures

Step	Procedure
H	<ol style="list-style-type: none"> 1. Vehicle Ignition: Key-OFF, Engine-OFF. 2. Disconnect the 10-way connector from the VS-400 Forward Looking Radar (FLR). 3. Measure for zero voltage on pins 10 and 9 on the harness connector. <ol style="list-style-type: none"> a. If the voltage is 0.5 volts or less. <ol style="list-style-type: none"> i. Proceed to Step I. b. If the voltage is greater than 0.5 volts, but less than battery voltage. <ol style="list-style-type: none"> i. Test Failed. Check FLR power supply wiring for sources of stray voltage or shorts to voltage. c. If the voltage is within 0.6 volts of the vehicle battery voltage measured in Step A: <ol style="list-style-type: none"> i. Test Failed. The FLR is improperly wired to battery power. Correct the wiring by connecting the FLR to ignition power and repeat Step.

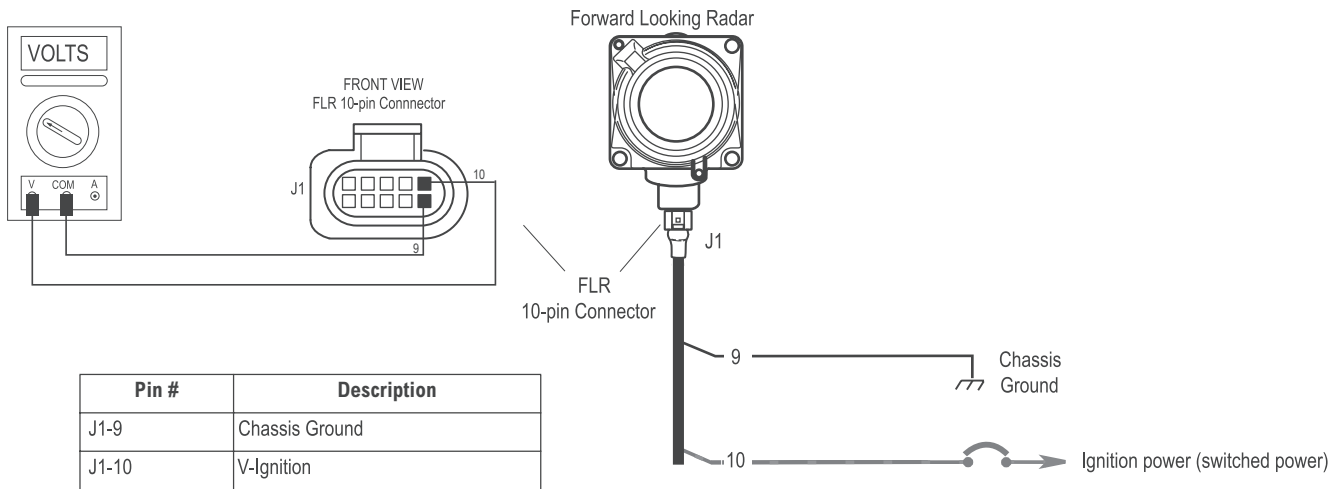

Pretest Procedures

Step	Procedure
I	<ol style="list-style-type: none"> 1. Vehicle Ignition: Key-ON, Engine-OFF. 2. Measure for ignition voltage on pins 10 and 9 of the harness connector. <ol style="list-style-type: none"> a. If the voltage is within 0.6 volts of the battery voltage measured in Step A. <ol style="list-style-type: none"> i. Proceed to Step J. b. If the voltage is less than 0.6 volts of the battery voltage measured in Step A or open. <ol style="list-style-type: none"> i. Test Failed. Check component fuse. Troubleshoot power supply to the FLR for open/corroded connections or shorts to ground and repeat Step.

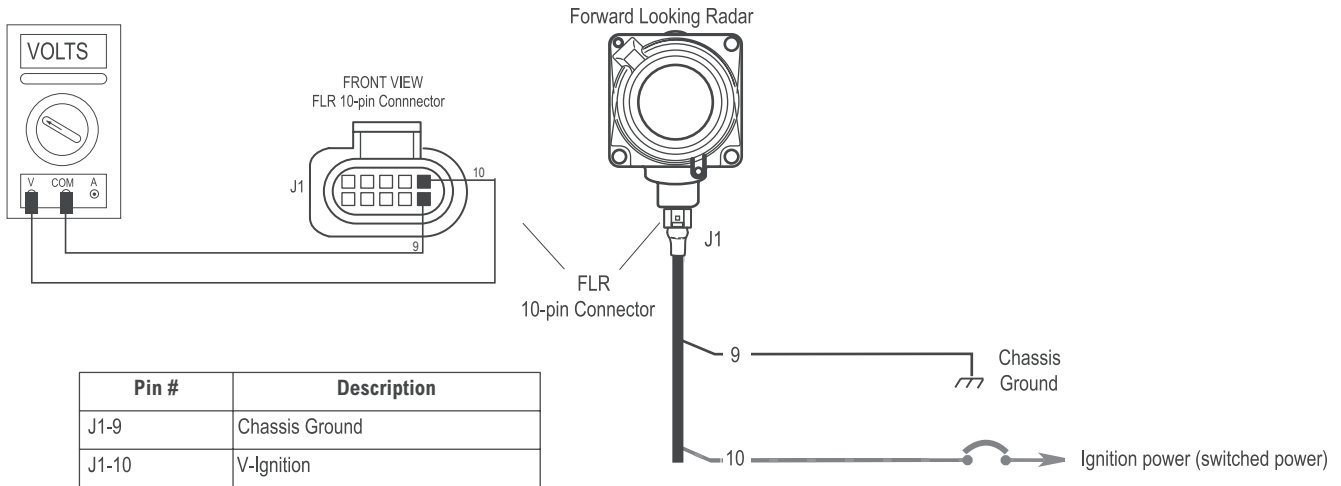

Pretest Procedures

Step	Procedure
J	<ol style="list-style-type: none"> 1. Vehicle Ignition: Key-ON, Engine-OFF. 2. Measure for J1939 data voltage on pins 4 and 9 of the FLR harness connector. (J1939 High to Ground) <ol style="list-style-type: none"> a. If the voltage is fluctuating between 2 to 5 volts. <ol style="list-style-type: none"> i. Proceed to Step K. b. If the voltage is a constant 0 volts. <ol style="list-style-type: none"> i. Test Failed. Check for open / loose connections in the vehicle's J1939 data link harness. (See Note) <p>Note: Refer to vehicle OEM repair manual or contact the OEM for more information on the J1939 data link harness.</p>

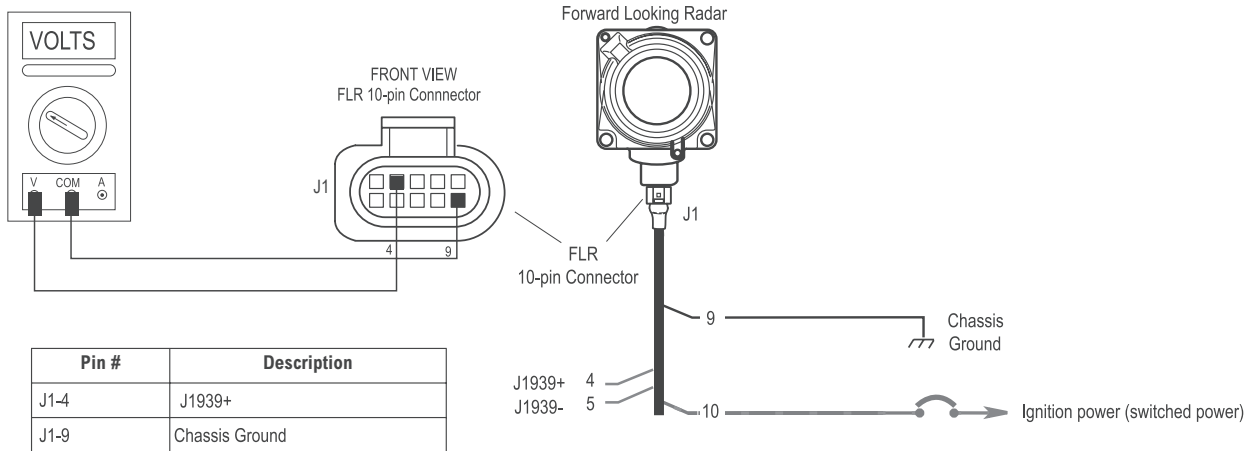

Pretest Procedures

Step	Procedure
K	<ol style="list-style-type: none"> 1. Vehicle Ignition: Key-ON, Engine-OFF. 2. Measure for J1939 data voltage on pins 5 and 9 of the FLR harness connector. (J1939 Low to Ground) <ol style="list-style-type: none"> a. If the voltage is fluctuating between 0 to 3 volts. <ol style="list-style-type: none"> i. Proceed to Step L. b. If the voltage is a constant 0 volts. <ol style="list-style-type: none"> i. Test Failed. Check for open / loose connections in the vehicle's J1939 data link harness. (See Note) <p>Note: Refer to vehicle OEM repair manual or contact the OEM for more information on the J1939 data link harness.</p>

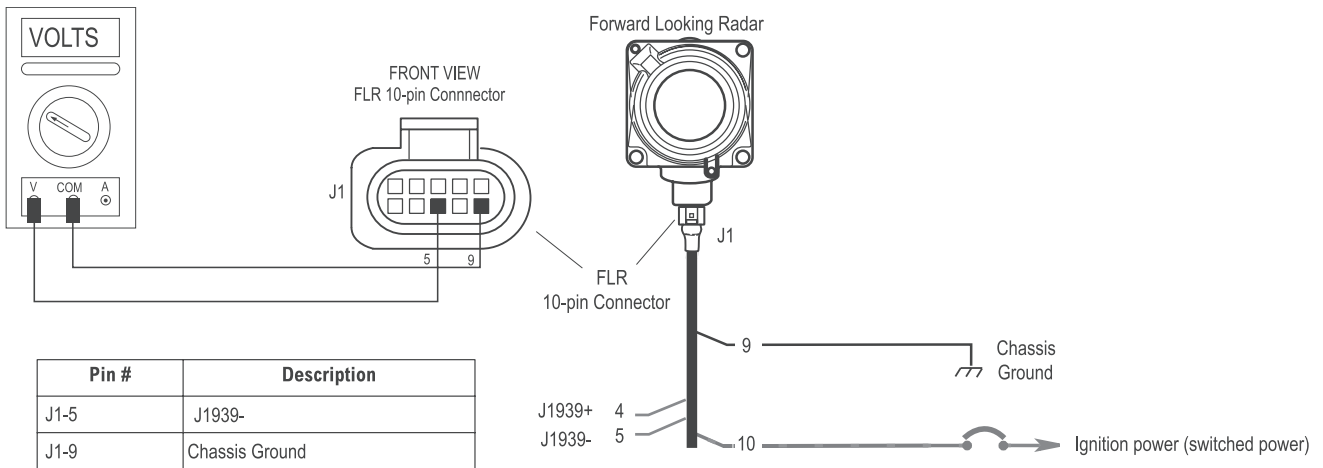

Pretest Procedures

Step	Procedure
L	<ol style="list-style-type: none"> 1. Vehicle Ignition: Key-OFF. 2. Measure the J1939 data link resistance across pins 4 and 5 of the FLR harness connector. (J1939 High to J1939 Low) <ol style="list-style-type: none"> a. If the resistance is between 57 and 63 ohms. <ol style="list-style-type: none"> i. Proceed to Step M. b. If the resistance is greater than 63 ohms or open (Infinite Resistance.) <ol style="list-style-type: none"> i. Test Failed. Check for missing J1939 data link terminating resistor(s) or open / loose connections in the vehicle's J1939 data link harness. (See Note) c. If the resistance is less than 57 ohms or near zero. <ol style="list-style-type: none"> i. Test Failed. Check for shorted connections in the vehicle's J1939 data link harness. Unplug all J1939 data link components from the data link to isolate a potential defective component. (See Note) <p>Note: Refer to vehicle OEM repair manual or contact the OEM for more information on the J1939 data link harness.</p>

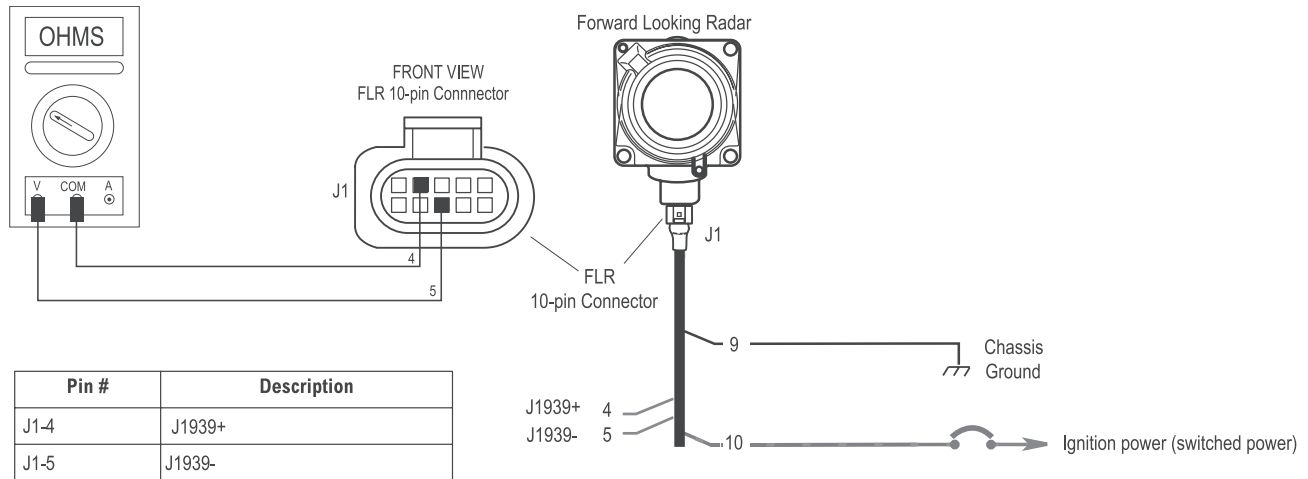

Pretest Procedures

Step	Procedure
M	<ol style="list-style-type: none"> 1. Vehicle Ignition: Key-OFF. 2. Measure the resistance across pins 4 and 9 (J1939 High to Ground). 3. Measure the resistance across pins 5 and 9 (J1939 Low to Ground). <ol style="list-style-type: none"> a. If the resistance is greater than 100K ohms or open (Infinite Resistance). <ol style="list-style-type: none"> i. Test Complete. b. If the resistance is between 0 to 100K ohms. <ol style="list-style-type: none"> i. Test Failed. Check for shorted connections in the vehicle's J1939 data link harness. Unplug all J1939 data link components from the data link to isolate a potential defective component. (See Note) <p>Note: Refer to vehicle OEM repair manual or contact the OEM for more information on the J1939 data link harness.</p>

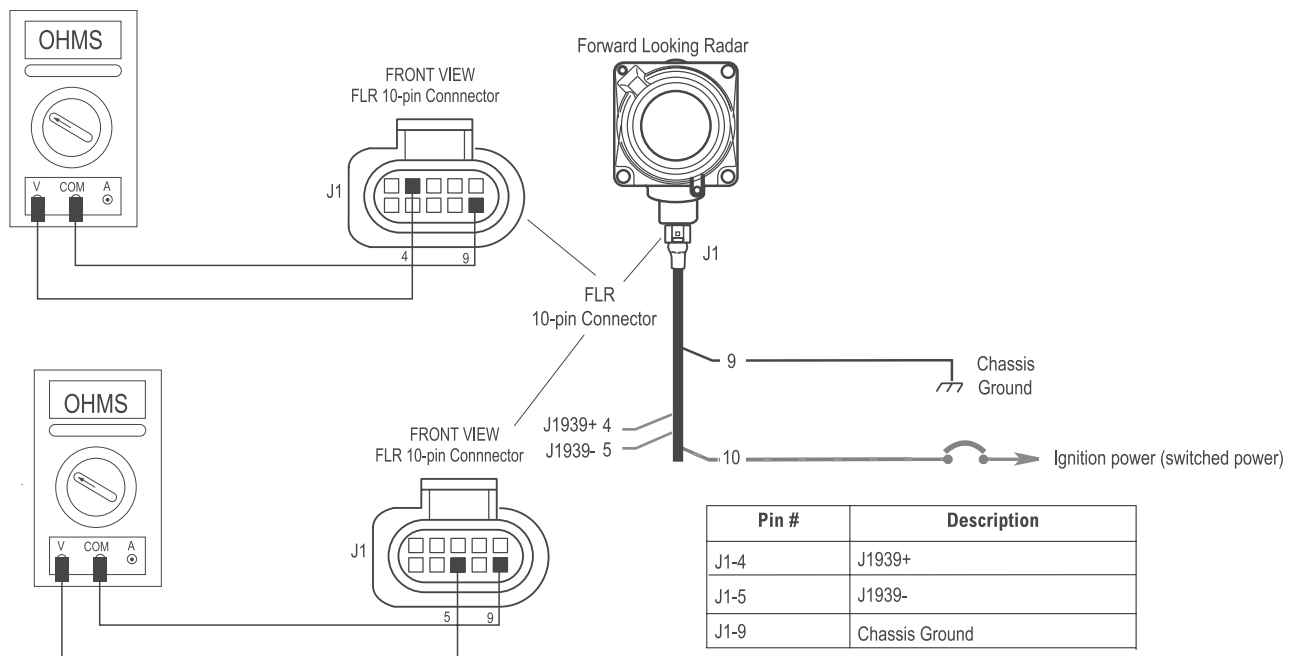

Component Code: 13 (SA 140, SPN 893, FMI 12) DIU Component Diagnostic Trouble Code (DTC)

Overview

This code indicates that the Driver Interface Unit (DIU) has detected an internal failure.

Diagnostic Trouble Code (DTC) Detection

At power up and during operation, the DIU performs a self-test to verify the operation of its internal components. If the device detects an internal failure, this Diagnostic Trouble Code (DTC) is set.

Symptom

The VS-400 Collision Warning System and SmartCruise® adaptive cruise control will fail to operate and the orange DTC light on the Driver Interface Unit will be illuminated. If SmartCruise® adaptive cruise control is enabled, the vehicle's cruise control may not operate while this Diagnostic Trouble Code (DTC) is active.

Possible Causes

Component failure

Repair Procedure

Active Diagnostic Trouble Code (DTC)	Steps to Perform
Code 13, FMI 12	<ol style="list-style-type: none">1. Replace Driver Interface Unit (DIU).2. Verify Diagnostic Trouble Code (DTC) has cleared.3. Test Complete.

Component Code: 14 (SA 42, SPN 886, FMI 12) FLR Component Diagnostic Trouble Code (DTC)

Overview

This code indicates that the Forward Looking Radar (FLR) has detected an internal failure.

Diagnostic Trouble Code (DTC) Detection

At power up and during operation, the FLR performs a self-test to verify the operation of its internal components. If the device detects an internal failure, the Diagnostic Trouble Code (DTC) is set.

Symptom

The Bendix™ VORAD® VS-400 Collision Warning System and the Bendix™ SmartCruise® adaptive cruise control will fail to operate and the orange DTC light on the Driver Interface Unit will be illuminated. If SmartCruise® adaptive cruise control is enabled, the vehicle's cruise control may not operate while this Diagnostic Trouble Code (DTC) is active.

Possible Causes

- FLR Software
- Component failure

Component Code: 25 (SA 42, SPN 898, FMI 13, 14) SmartCruise® Adaptive Cruise Control Configuration Error

Overview

This code indicates that the VS-400 Forward Looking Radar (FLR) has detected a SmartCruise configuration or compatibility issue with the engine.

Diagnostic Trouble Code (DTC) Detection

At power up, the FLR attempts to verify if the engine controller is SmartCruise® adaptive cruise control compatible and has its Adaptive Cruise Control (ACC) setting(s) enabled. If the FLR determines that one of these conditions is false, this Diagnostic Trouble Code (DTC) is set.

- Code 25, FMI 13 - Engine is not configured for SmartCruise® adaptive cruise control.
- Code 25, FMI 14 - Engine ID is not recognized as SmartCruise® adaptive cruise control compatible.

Symptom

When this code is active, the Bendix™ VORAD® VS-400 Collision Warning will continue to operate, but the Bendix™ SmartCruise® adaptive cruise control will not. The DIU will indicate SmartCruise® adaptive cruise control is not operational and the orange DTC light will be illuminated.

Possible Causes

- FMI 13 - The engine controller setting for Adaptive Cruise Control is not enabled.
- FMI 14 - The engine does not support the Adaptive Cruise Control function or is not compatible with the VS-400 system.

Component Code: 32 (SA 140, SPN 639, FMI 2) DIU J1939 Message Error

Overview

This code indicates that the Driver Interface Unit (DIU) has detected gaps or missing messages from the Forward Looking Radar (FLR) on the J1939 data link.

Diagnostic Trouble Code (DTC) Detection

At power up and during operation, the DIU and FLR continuously communicate with each other on the J1939 data link. If the DIU detects gaps occurring in the messages from the FLR or the FLR stops communicating, the Diagnostic Trouble Code (DTC) is set.

Symptom

The Bendix™ VORAD® VS-400 Collision Warning and the Bendix™ SmartCruise® adaptive cruise control will fail to operate and the orange DTC light on the Driver Interface Unit will be illuminated. If SmartCruise® adaptive cruise control is enabled, the vehicle's cruise control may not operate while this Diagnostic Trouble Code (DTC) is active.

Possible Causes

- Loose, corroded, or open J1939 data link connections
- Missing J1939 data link terminating resistor(s)
- Loss of power supply to the FLR
- Malfunctioning FLR

Repair Procedure

Active Diagnostic Trouble Code (DTC) Steps to Perform

Code 32, FMI 2	1.	Perform the "Component Power Supply Test" in the Appendix.
	2.	Check the vehicle's J1939 data link for poor connections or missing terminating resistors.
	3.	Verify that all ECU's on the data link are functional and not interfering with data link communications. Note: Isolate any suspect malfunctioning ECU's by disconnecting them from the data link.
	4.	Perform Electrical Pretest to check data link and harness connections and harness to the VS-400 components.
	5.	If the Diagnostic Trouble Code (DTC) remains active with no Diagnostic Trouble Code (DTC) found, replace the FLR and check operation.
	6.	Test Complete.

Component Code: 33 (SA 42, SPN 639, FMI 2) FLR J1939 Message Error

Overview

This code indicates that the Forward Looking Radar (FLR) has detected gaps or missing messages from the Driver Interface Unit (DIU) or other devices on the J1939 data link.

Diagnostic Trouble Code (DTC) Detection

At power up and during operation, the FLR, DIU, and other devices continuously communicate with each other on the J1939 data link. If the FLR detects gaps occurring in the messages from one of the devices or one of the devices stops communicating, the Diagnostic Trouble Code (DTC) is set.

Symptom

The Bendix™ VORAD® VS-400 Collision Warning and the Bendix™ SmartCruise® adaptive cruise control will fail to operate and the orange DTC light on the Driver Interface Unit will be illuminated. If SmartCruise® adaptive cruise control is enabled, the vehicle's cruise control may not operate while this Diagnostic Trouble Code (DTC) is active.

Possible Causes

- Loose, corroded, or open J1939 data link connections
- Missing J1939 data link terminating resistor(s)
- Malfunctioning device on the J1939 data link causing other ECU's to fail communications
- Loss of power supply to the DIU
- Malfunctioning DIU

Repair Procedure

Active Diagnostic Trouble Code (DTC)	Steps to Perform
Code 33, FMI 2	<ol style="list-style-type: none"> 1. Perform the "Component Power Supply Test" in the Appendix. 2. Check the vehicle's J1939 data link for poor connections or missing terminating resistors. 3. Verify that all ECU's on the data link are functional and not interfering with data link communications. Note: Isolate any suspect malfunctioning ECU's by disconnecting them from the data link. 4. Perform Electrical Pretest to check data link and harness connections and harness to the VS-400 components. 5. If the Diagnostic Trouble Code (DTC) remains active with no Diagnostic Trouble Code (DTC) found, replace the DIU and check operation. 6. Test Complete.

Component Code: 35, 36 (SA 42, SPN 639, FMI 9) J1939 Data Link Diagnostic Trouble Code (DTC)

Overview

This code indicates that the VS-400 Forward Looking Radar (FLR) or the Driver Interface Unit (DIU) has detected that there is a J1939 data link Diagnostic Trouble Code (DTC) condition.

Diagnostic Trouble Code (DTC) Detection

At power up and throughout operation, the FLR, DIU, and other devices continuously communicate with each other on the J1939 data link. If there is a J1939 Diagnostic Trouble Code (DTC) condition, such as a corrupted message, incorrect message formatting, or the complete loss of all J1939 data, the Diagnostic Trouble Code (DTC) is set.

- Code 35, FMI 9 - The DIU has detected a J1939 Diagnostic Trouble Code (DTC) condition.
- Code 36, FMI 9 - The FLR has detected a J1939 Diagnostic Trouble Code (DTC) condition.

Symptom

The Bendix™ VORAD® VS-400 Collision Warning and the Bendix™ SmartCruise® adaptive cruise control will fail to operate and the orange DTC light on the Driver Interface Unit will be illuminated. If SmartCruise® adaptive cruise control is enabled the vehicle's cruise control may not operate while this Diagnostic Trouble Code (DTC) is active.

Possible Causes

- Loose, corroded, or open J1939 data link connections
- Malfunctioning device on the J1939 data link causing other ECU's to fail communications.

Repair Procedure

Active Diagnostic Trouble Code (DTC)	Steps to Perform
Code 35, FMI 9 OR Code 36, FMI 9	<ol style="list-style-type: none"> 1. Perform the "Component Power Supply Test" in the Appendix. 2. Check the vehicle's J1939 data link for poor connections, opens or short circuits. 3. Verify that all ECUs on the data link are functional and broadcasting data per the manufacturer's specifications. Note: Isolate any suspect malfunctioning ECU's by disconnecting them from the data link. 4. Perform Electrical Pretest to check data link connections to the VS-400 components. 5. Test Complete.

Component Code: 39 (SA 42, SPN 158, FMI 3, 4) FLR Supply Voltage Out of Range

Overview

This code indicates that the Forward Looking Radar (FLR) has determined that the supply voltage is, or was, out of range.

Diagnostic Trouble Code (DTC) Detection

At power up and during operation, the FLR monitors supply voltage. If the supply voltage fails outside the normal operating range (+9 to 16 Vdc) the Diagnostic Trouble Code (DTC) will set and the FLR will power down to prevent damage. In some cases the FLR may power down before the Diagnostic Trouble Code (DTC) is set. This Diagnostic Trouble Code (DTC) may also trigger Driver Interface Diagnostic Trouble Codes (DTCs) 32 and 35 for loss of J1939 messages. In this case correcting this condition should clear the other Diagnostic Trouble Codes (DTCs).

Symptom

The Bendix™ VORAD® VS-400 Collision Warning and the Bendix™ SmartCruise® adaptive cruise control will fail to operate and the orange DTC light on the Driver Interface Unit will be illuminated. If SmartCruise® adaptive cruise control is enabled, the vehicle's cruise control may not operate while this Diagnostic Trouble Code (DTC) is active.

Possible Causes

- FMI 3 - Supply voltage to the FLR is too low.
- FMI 4 - Supply voltage to the FLR is too high.

Repair Procedure

Active Diagnostic Trouble Code (DTC)	Steps to Perform
Code 39, FMI 3, 4	<ol style="list-style-type: none">1. Repair supply voltage to FLR. The FLR voltage should be 12 Vdc ignition power.2. Verify Diagnostic Trouble Code (DTC) condition has been cleared.3. Test Complete.

Component Code: 41, 42 (SPN 1703, 1704, FMI 4, 5) Driver Interface Unit External Speaker Diagnostic Trouble Code (DTC)

Overview

Most vehicles use the DIU as a source of audio alerts, however, the chassis manufacturer has the option to install an external chassis speaker system. For systems with external speaker systems, this code indicates that the VS-400 Driver Interface Unit (DIU) has detected that the external speaker circuit has an open circuit or short to ground.

Diagnostic Trouble Code (DTC) Detection

If the DIU is enabled for external speakers and the speaker circuit becomes open or shorted to ground this code is set active.

- Code 41, FMI 4 - RH Speaker circuit is shorted to ground
- Code 41, FMI 5 - RH Speaker circuit is open
- Code 42, FMI 4 - LH Speaker circuit is shorted to ground
- Code 42, FMI 5 - LH Speaker circuit is open

Symptom

When this code is active, the Bendix™ VORAD® VS-400 system will not operate and the orange DTC fail light on the DIU will be illuminated. If SmartCruise® adaptive cruise control is enabled and the engine is enabled for adaptive cruise, the vehicle's cruise control may not operate.

Possible Causes

- Loose, corroded, or open external speaker connections
- Pinched wire or shorted external speaker
- External speaker configuration enabled without external speaker connected

Repair Procedure

Active Diagnostic Trouble Code	Steps to Perform
Code 41, FMI 4	<ol style="list-style-type: none"> 1. Check for a short to ground by measuring the resistance between Pin-1 and Pin-5 of the DIU harness connector. <ol style="list-style-type: none"> a. If value is less than 2 ohms, test failed. Check external speaker and harness for short to ground. Repair as needed. b. If value is 2 to 5 ohms, continue to next step. 2. Replace DIU and verify Diagnostic Trouble Code (DTC) condition has cleared. 3. Test Complete.

Diagnostic Trouble Code (DTC) Isolation Procedures

Code 41, FMI 5	<ol style="list-style-type: none"> 1. Check to see if Pin-1 of the DIU harness connector is populated. <ol style="list-style-type: none"> a. If no, test complete. The DIU does not utilize a RH external speaker. Disable the RH external speaker output using diagnostic software. b. If yes, continue to next step. 2. Check for an open circuit in the external speaker by measuring the resistance between Pin-1 and Pin-5 of the DIU harness connector. <ol style="list-style-type: none"> a. If value is greater than 5 ohms, test failed. Check external speaker and harness for an open circuit. Repair as needed. b. If value is 2 to 5 ohms, continue to next step. 3. Replace DIU and verify Diagnostic Trouble Code (DTC) condition has cleared. 4. Test Complete.
Code 42, FMI 4	<ol style="list-style-type: none"> 1. Check for a short to ground by measuring the resistance between Pin-2 and Pin-5 of the DIU harness connector. <ol style="list-style-type: none"> a. If value is less than 3 ohms, test failed. Check external speaker and harness for short to ground. Repair as needed. b. If value is 2 to 5 ohms, continue to next step. 2. Replace DIU and verify Diagnostic Trouble Code (DTC) condition has cleared. 3. Test Complete.
Code 42, FMI 5	<ol style="list-style-type: none"> 1. Check to see if Pin-2 of the DIU harness connector is populated. <ol style="list-style-type: none"> a. If no, test complete. The DIU does not utilize a LH external speaker. Disable the LH external speaker output using diagnostic software. b. If yes, continue to next step. 2. Check for an open circuit in the external speaker by measuring the resistance between Pin-1 and Pin-5 of the DIU harness connector. <ol style="list-style-type: none"> a. If value is greater than 5 ohms, test failed. Check external speaker and harness for an open circuit. Repair as needed. b. If value is 2 to 5 ohms, continue to next step. 3. Replace DIU and verify Diagnostic Trouble Code (DTC) condition has cleared. 4. Test Complete.

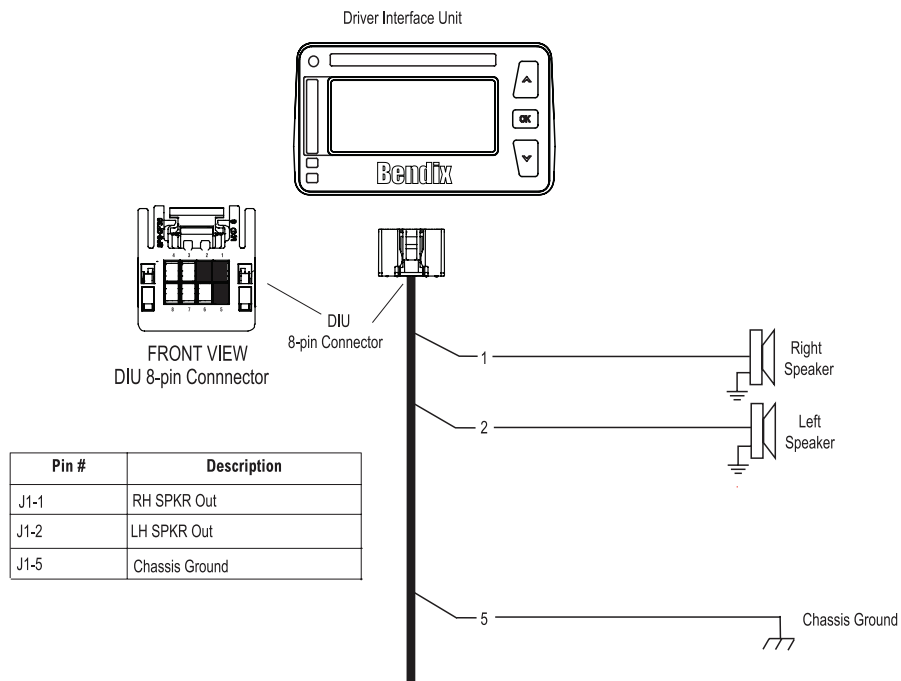

Component Code: 91 (SA 42, SPN 886, FMI 7) Forward Looking Radar Out of Alignment

Overview

This code indicates that the Forward Looking Radar (FLR) has determined that the radar is misaligned.

Diagnostic Trouble Code (DTC) Detection

When the vehicle is in motion, the FLR will calculate the vehicle's center thrust axis and compare this to the radar's physical horizontal alignment to determine if the radar is aligned properly. The radar software can compensate for a very slight misalignment (+ / - 1°). When the FLR has determined that the position is off by more than what it can correct for, the Diagnostic Trouble Code (DTC) is set.

Symptom

The Bendix™ VORAD® VS-400 Collision Warning System and the Bendix™ SmartCruise® adaptive cruise control will continue to operate, however, the radar's ability to detect objects at an angle will be compromised. The Driver Interface Unit (DIU) will display a message indicating the Diagnostic Trouble Code (DTC) condition.

Possible Causes

- Loose or Misaligned Radar

Repair Procedure

Active Diagnostic Trouble Code	Steps to Perform
Code 91, FMI 7	<ol style="list-style-type: none">1. Perform the Forward Looking Radar Alignment procedure located in the Appendix.2. Road test vehicle and make sure the Diagnostic Trouble Code (DTC) condition has cleared.3. Test Complete.

Component Code: 92 (SA 42, SPN 886, FMI 14) Forward Looking Radar Not Detecting Objects or Radar Blocked

Overview

This code indicates that the Forward Looking Radar (FLR) has not detected a target in an excessive amount of time or has become blocked.

Diagnostic Trouble Code (DTC) Detection

When the FLR has gone a period of time without receiving any reflected radar signals this Diagnostic Trouble Code (DTC) is set. This may simply indicate that the vehicle has been in an extremely desolate area without any vehicles or objects to reflect its radar signals. Non-vehicular objects such as road signs, highway overpasses and background trees should provide enough radar signals to prevent this Diagnostic Trouble Code (DTC) from being set. This Diagnostic Trouble Code (DTC) may also indicate that the FLR has become blocked by mud, snow, ice, or other debris.

Symptom

The Bendix™ VORAD® VS-400 Collision Warning System and the Bendix™ SmartCruise® adaptive cruise control will fail to operate, however, the driver will have access to conventional cruise control. The Driver Interface Unit (DIU) will illuminate an orange DTC light and display a message indicating the Diagnostic Trouble Code (DTC) condition. If the VS-400 system once again begins to detect objects, the condition will clear and the system will resume normal operation.

Possible Causes

- Obstructed Radar View
- Correct Operation, but with a lengthy time since the last radar object was detected

Repair Procedure

Active Diagnostic Trouble Code (DTC)	Steps to Perform
Code 92, FMI 14	1. Check the Forward Looking Radar for debris buildup (snow, mud, etc.) or if the radar's view is being obstructed. Note: This Diagnostic Trouble Code (DTC) is automatically set inactive after each power cycle.
	2. Road test vehicle and make sure the Diagnostic Trouble Code (DTC) condition has cleared.
	3. Test Complete.

Component Code: 95 (SA 42, SPN 171, FMI 0, 1) Forward Looking Radar Ambient Temperature Out of Range

Overview

This code indicates that the Forward Looking Radar (FLR) has determined that the ambient temperature it is operating in is outside the component's operating range.

Diagnostic Trouble Code (DTC) Detection

At power up and throughout operation, the FLR monitors the outside air temperature. When the temperature reaches the limits of the FLR's functional ability to operate, this Diagnostic Trouble Code (DTC) will set.

Symptom

When this code is active, the Bendix™ VORAD® VS-400 system will not operate and the orange DTC fail light will be illuminated. If SmartCruise® adaptive cruise control is enabled and the engine is enabled for adaptive cruise, the vehicle's cruise control may not operate.

Possible Causes

- FMI 0 - Ambient air temperature too low for FLR operation
- FMI 1 - Ambient air temperature too high for FLR operation

Repair Procedure

Active Diagnostic Trouble Code	Steps to Perform
Code 92, FMI 0, 1	<ol style="list-style-type: none">1. As long as the FLR temperature remains outside of the product specifications, this code will remain active. You may wish to bring the truck into a controlled temperature environment, such as a garage, for a period of time. Cycle the ignition and attempt to duplicate the Diagnostic Trouble Code (DTC).2. If the Diagnostic Trouble Code (DTC) continues to be active in another temperature environment, contact Bendix for more information.

Side Object Detection (SOD)

System Operation

Overview

This section covers the operation of the Side Object Detection (SOD) system. The Side Object Detection system is a stand-alone system which can be installed as an all-on feature for the Bendix™ VORAD® VS-400 Forward Looking system. It is powered independently from the forward looking system and utilizes its own Driver Display Unit which is typically located on the windshield pillar.

System Power Up

When the vehicle's ignition is turned to the ON position, the SOD display will power up by initially illuminating both the red and yellow lamps, indicating the system is performing its self test. Once the self test is complete and no objects are within a 15 foot radius of the sensor, the red lamp turns off while the yellow lamp remains illuminated, indicating the system is operational.

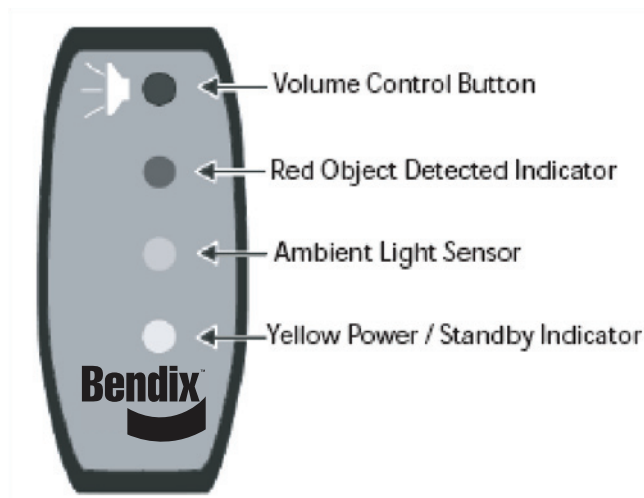

Normal Operation

When an object is detected within the sensor's detection zone, the driver display illuminates the red detect lamp. During normal operation, the display will toggle between illuminating either the yellow or the red lamps, but never both at the same time (See SOD Failure Diagnostic Procedure).

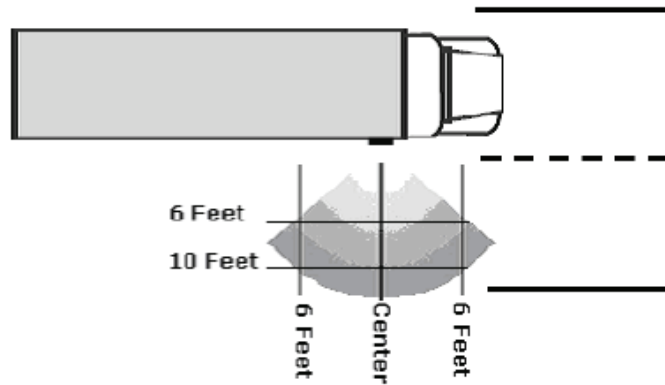

Alert Tone

If the turn signal is active when an object is detected, the Driver Display Unit will sound an alert tone. An alert tone is heard only once each time the turn signal is activated. The sensor is wired to the turn signal on the same side of the vehicle in which the sensor is mounted (ie: RH Turn Signal causes a RH mounted SOD display to tone).

Diagnostic Trouble Code (DTC) Isolation Procedures

System Diagnostic Trouble Code (DTC) (Both Red and Yellow Lamps ON)

Overview

The Side Object Detection (SOD) Driver Display Unit illuminates both the red and yellow lamps to indicate a system Diagnostic Trouble Code (DTC).

Diagnostic Trouble Code (DTC) Detection

Whenever the SOD Driver Display loses communications with the side sensor, or if the sensor reports an internal failure, the display will illuminate both the red and yellow lamps.

Symptom

The Side Object Detection system will fail to detect objects in its detection zone.

Possible Causes

- Broken or shorted wire between the SOD display and the SOD sensor
- Malfunctioning Side Sensor

Repair Procedure

Condition	Steps to Perform
Red and Yellow ON	<ol style="list-style-type: none"> 1. Disconnect the Driver Display and the Side Sensor from the interconnect harness. 2. Test the resistance between Pin-3 of the Driver Display harness connector and chassis ground. <ol style="list-style-type: none"> a. If greater than 100K ohms, continue to next step. b. If less than 100K ohms, test failed. Repair harness. 3. Test resistance between Pin-3 of the Driver Display harness connector and Pin-3 of the Side Sensor harness connector. <ol style="list-style-type: none"> a. If less than 0.9 ohms, continue to next step. b. If greater than 0.9 ohms, test failed. Repair harness. 4. Test complete. Replace Side Sensor.

1. Forward Looking Radar Alignment

Alignment



The alignment of the Forward Looking Radar is critical to the correct operation of the Bendix™ VORAD® VS-400 system. Improper alignment can cause the system to improperly detect objects in the vehicle's path. Every precaution should be taken to ensure the VS-400 system alignment (both horizontal and vertical), is correct.

Alignment of the Forward Looking Radar is a repetitive process of adjusting the vertical and horizontal axis using the bracket screws. The vertical alignment must be completed with a digital level. The horizontal alignment is started by referencing the FLR against fixed positions on the bumper and using a digital level. The horizontal alignment is completed by performing a calibration procedure with the Service Ranger 3 diagnostic software while driving the unit equipped with the VORAD system.

Note: The vehicle must be parked on a level surface. If the vehicle is on an angled surface, then level compensations must be made to ensure proper alignment.

Below are steps for a typical alignment procedure. Other companies, such as Hunter Engineering Company (11250 Hunter Drive, Bridgeton, MO 63044, 314-731-3020), can also be contacted to establish alignment using other professional alignment equipment.

2. Vertical Alignment

The steps for vertical alignment are as follows:

1. Hold a digital level against the flat surface of the mounting bracket.
2. Use a 5/32" Allen wrench to loosen the locking screws.

Note: Failure to loosen both locking screws will result in damage to the alignment bracket.

3. Adjust the alignment screws until the digital level reads down $0^\circ \pm .2^\circ$.
4. Once aligned, tighten the locking screws.

Note: The illustration below shows a typical mounting and mounting bracket. The design may vary.

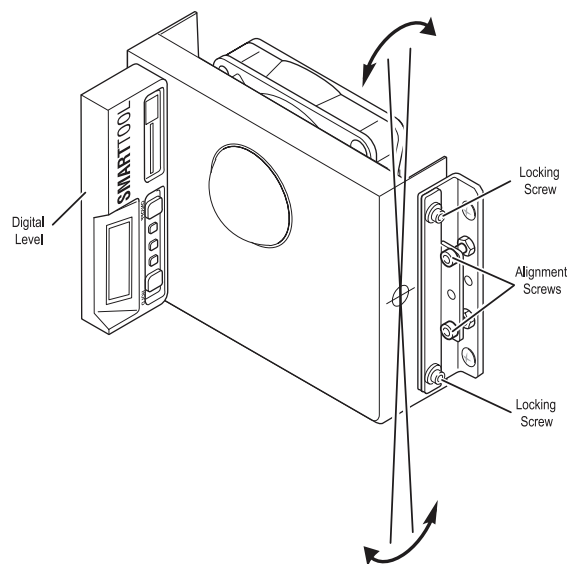

3. Horizontal Alignment

The Forward Looking Radar must be facing straight ahead (azimuth) of the vehicle in order to optimally detect objects in the vehicle path.

1. Select two truck reference points that are identical and symmetrical about the truck centerline. Ensure the reference points are equally aligned. Items such as fenders and headlights should not be damaged or distorted; otherwise the alignment will be inaccurate.
2. Center a 4'-6" (1-2m) straight edge across a flat surface of the forward looking radar bracket.
3. Measure the distance between the reference points and the face of the straight edge.

4. Use a 5/32" Allen wrench to loosen the locking screws.

Note: Failure to loosen both locking screws will result in damage to the alignment bracket.

5. Adjust the alignment screw until the two measurement points are equal within +/- 0.1" (2.54mm).
6. Once the measurements are equal for both of the reference points, tighten the locking screws.
7. Check both the vertical and horizontal alignment:
 - a. Re-measure the reference points to ensure they are equal.
 - b. Use the digital level to verify the vertical alignment is still face down 0° from vertical \pm .2°.

Note: The illustration below shows a typical mounting and mounting bracket. The design may vary.

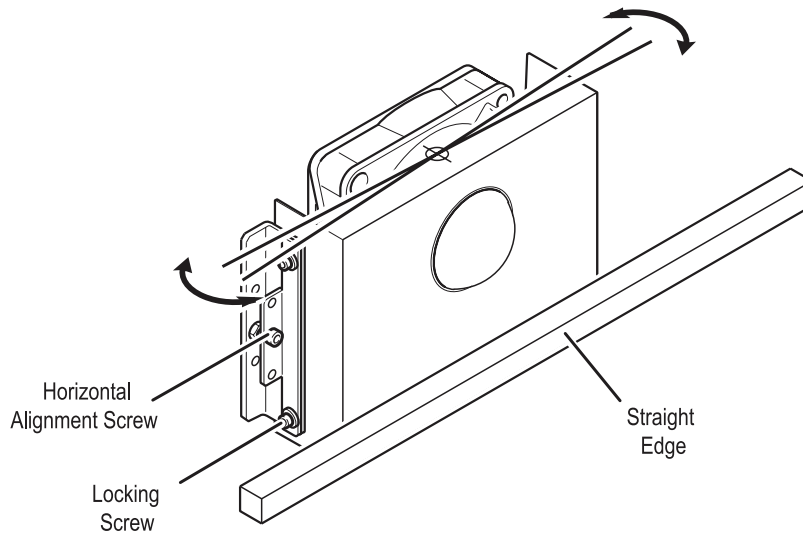

Calibrating the FLR Horizontal Alignment

After the physical horizontal alignment has been conducted on the chassis, there is a calibration procedure that should be implemented prior to delivery to the customer. This can also be performed as a service function at any point in time, if required. The calibration procedure requires the use of diagnostic software on a mobile computer that can be operated in the cab while the vehicle is in motion.

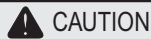

This procedure requires two people. The driver must not attempt to perform the calibration procedure while driving the vehicle.

In order to perform this procedure, the VORAD equipped vehicle must be traveling on a straight road at a speed above 30 mph behind a target vehicle traveling in the same lane. The Bendix™ VORAD®-equipped vehicle should be placed into SmartCruise® mode behind this target vehicle. If the VORAD® system is not Bendix™ SmartCruise® adaptive cruise control-equipped, position the vehicle manually 200 to 300 feet behind the target vehicle. At highway speeds, this can be approximated by the VORAD® DIU displaying a following distance of "2 seconds" or "3 seconds."

Double click on the option for "VORAD® VS-400 Alignment Tests."

Follow the steps shown on the diagnostic software.

Continue to run the truck for a period of time (2-5 min), monitoring the azimuth value. As long as the vehicle the VORAD® system is tracking is in the same lane, the azimuth position should be 0°, but fluctuations in driving techniques may cause the vehicle to drift +/- 0.3°. If this value cannot be consistently kept, click the "Reset" button again and monitor the azimuth position. If the position is consistently more than 0.5° or less than -0.5°, the FLR horizontal alignment must be adjusted based on the average azimuth position.

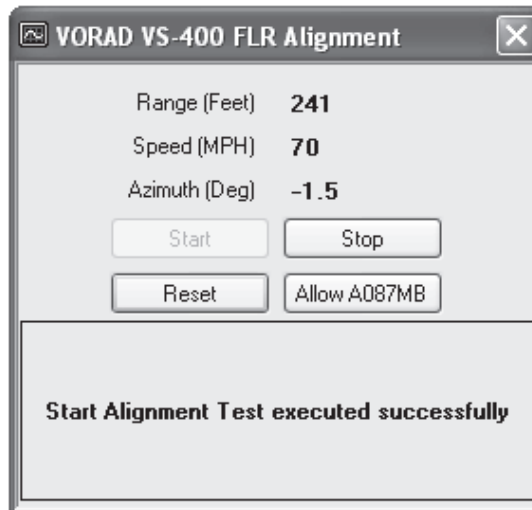

Note: For best results it is recommended that the driver perform the alignment test for 2-5 minutes to verify correct tracking of vehicles in the same lane.

Fine-Tuning the Horizontal Alignment

If the alignment function in the diagnostic software continuously shows an azimuth value greater than 0.5° or less than -0.5°, then the FLR needs to be physically adjusted in the horizontal direction beyond that already completed.

Center FLR Azimuth Position (FLR aligned correctly)

If the alignment function consistently shows an azimuth value of 0° +/- 0.5° when tracking a vehicle in the same lane, then the FLR is properly centered. In this case, the FLR does not need to be further aligned and the procedure is complete.

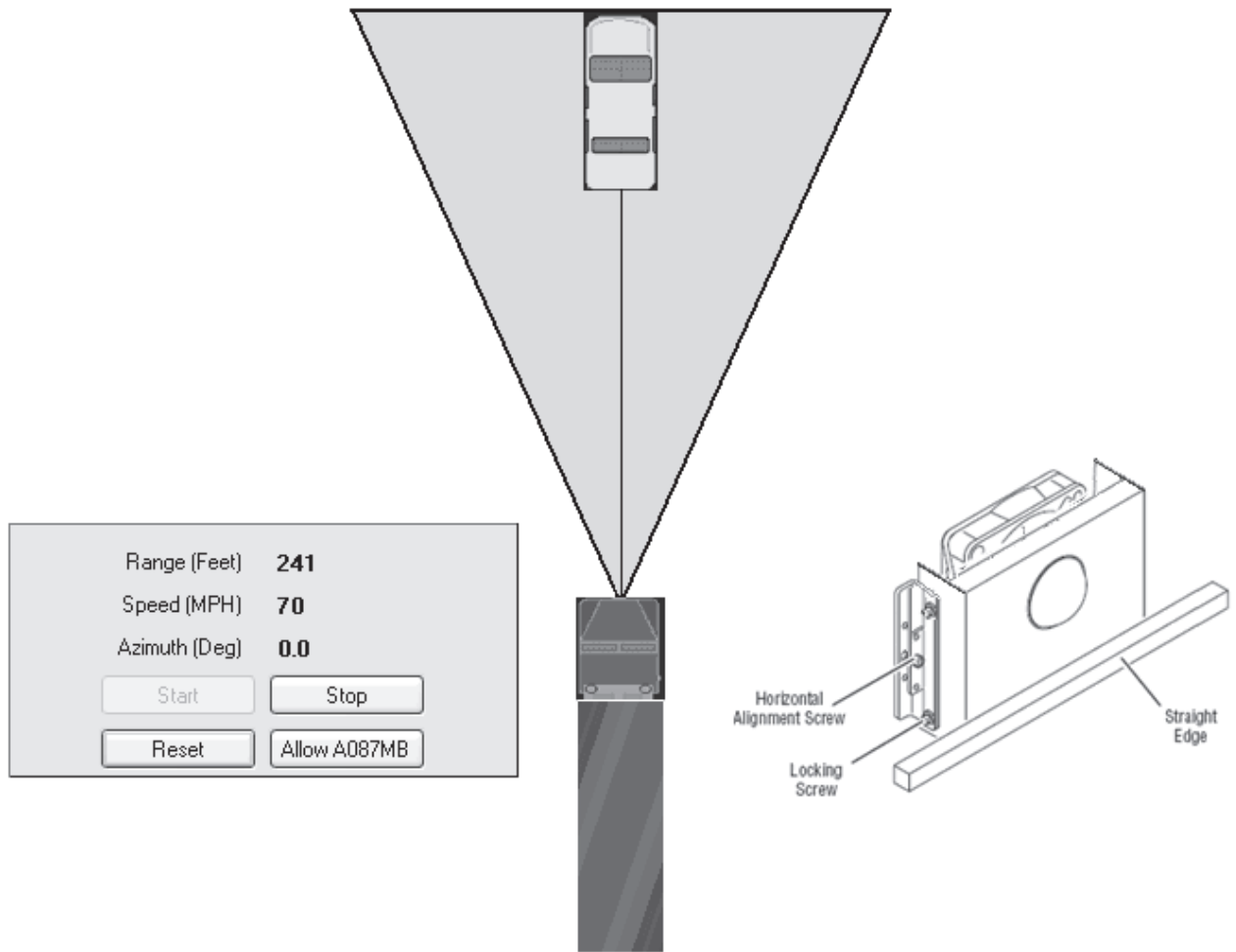

Negative Azimuth Adjustment (FLR too far to the left)

If the alignment function shows a positive value, then the FLR is adjusted too far to the left, when looked at from the driver's seat. The radar needs to be adjusted to the driver's right. To accommodate this, adjust the horizontal alignment screw by turning it in a clockwise direction, when viewed from the front of the vehicle. Each full rotation of the alignment screw adjusts for approximately 0.2° of azimuth position from the alignment function. For example, if the azimuth position was 0.5° , then the alignment screw should be adjusted $2\frac{1}{2}$ turns clockwise.

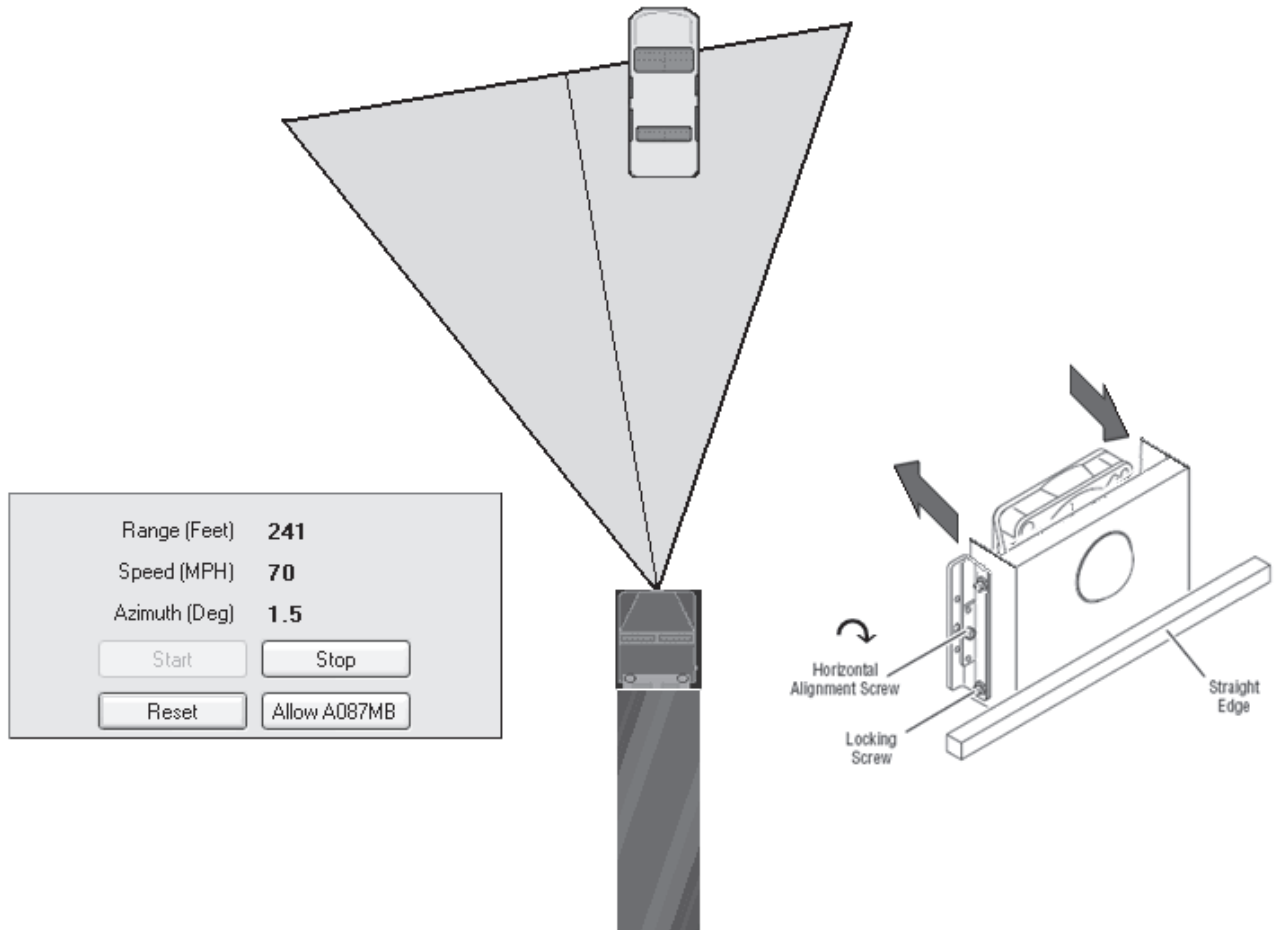

After adjustment of the FLR, perform the calibration procedure again to verify proper alignment.

Positive Azimuth Adjustment (FLR too far to the Right)

If the alignment function shows a negative value, then the FLR is adjusted too far to the right, when looked at from the driver's seat. The radar needs to be adjusted to the driver's left. To accommodate this, adjust the horizontal alignment screw, by turning it in a counter-clockwise direction, when viewed from the front of the vehicle. Each full rotation of the alignment screw adjusts for approximately 0.2° of azimuth position from the alignment function. For example, if the azimuth position was -0.5° , then the alignment screw should be adjusted $2\frac{1}{2}$ turns counter-clockwise.

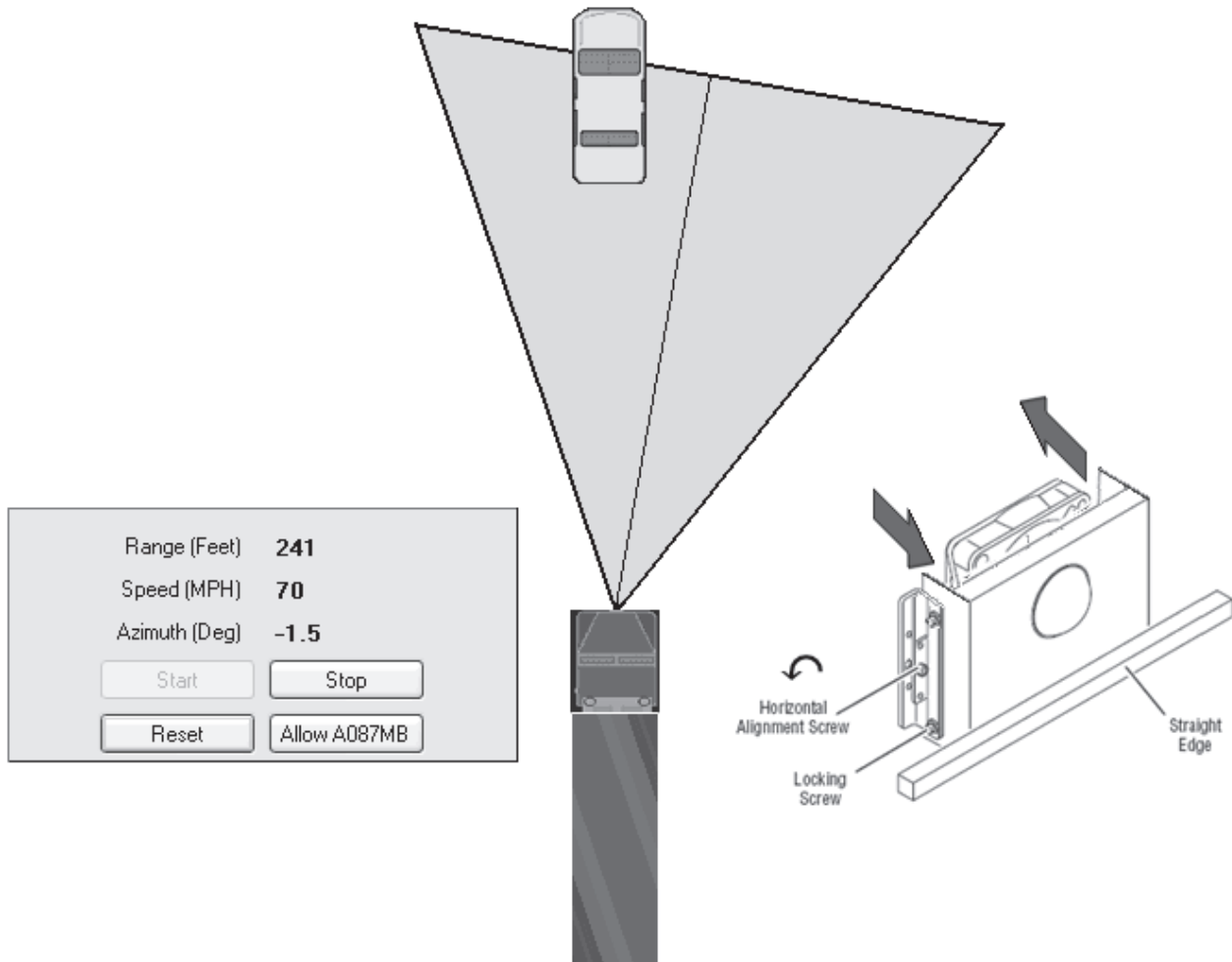

After adjustment of the FLR, perform the calibration procedure again to verify proper alignment.

4. Component Power Supply Test

Overview

The base Bendix™ VORAD® VS-400 system consists of two components, the FLR and DIU. Both should be powered by the main ignition power supply (12 Vdc). If one of these components is incorrectly connected to constant battery power or a secondary ignition source other than the main ignition power supply bus, there is the potential for J1939 communication Diagnostic Trouble Code (DTC) between the FLR and the DIU. These include, but are not limited to, Diagnostic Trouble Codes (DTCs) 32 and 33. If these Diagnostic Trouble Codes (DTCs) appear after the installation of a new VS-400 system or if the system is suspected of having this problem, perform this test to verify proper ignition power source to the FLR and the DIU.

Verifying Ignition Power to the DIU

Step	Procedure
A	<ol style="list-style-type: none"> 1. Vehicle Ignition: Key-OFF, Engine-OFF. 2. Disconnect the 8-way connector from the back of the VS-400 Driver Interface Unit (DIU). 3. Measure for zero voltage on pins 4 and 5 on the harness connector. <ol style="list-style-type: none"> a. If the voltage is 0.5 volts or less. <ol style="list-style-type: none"> i. Proceed to Step B. b. If voltage is greater than 0.5 volts but less than battery voltage. <ol style="list-style-type: none"> i. Test Failed. Check DIU power supply wiring for sources of stray voltage or shorts to voltage. c. If the voltage is within 0.6 volts of the battery voltage measured in Step A. <ol style="list-style-type: none"> i. Test Failed. The DIU is improperly wired or shorted to a battery power source. Correct the wiring by connecting the DIU to the main ignition power supply bus and repeat Step.

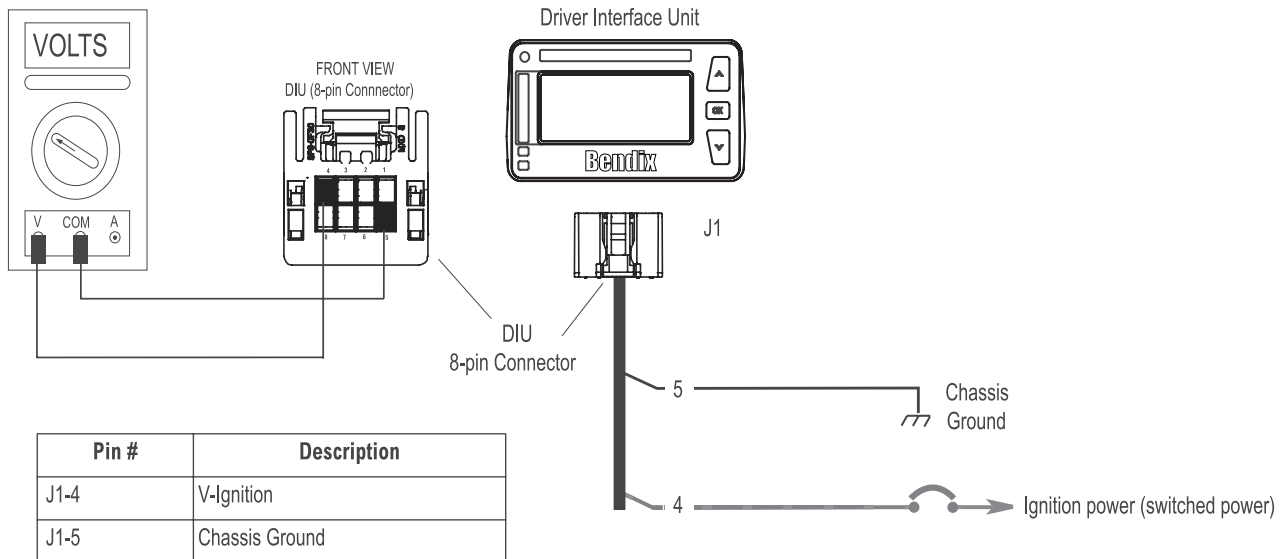

Step	Procedure
B	<ol style="list-style-type: none"> 1. Vehicle Ignition: Key-ON, Engine-OFF. 2. Measure for ignition voltage on pins 4 and 5 on the harness connector. <ol style="list-style-type: none"> a. If the voltage is within 0.6 volts of the battery voltage measured in Step A. <ol style="list-style-type: none"> i. Proceed to Step C. b. If voltage is less than 0.6 volts of the battery voltage measured in Step A or open. <ol style="list-style-type: none"> i. Test Failed. Check component fuse. Troubleshoot power supply to the DIU for open / corroded connections or shorts to ground and repeat Step.

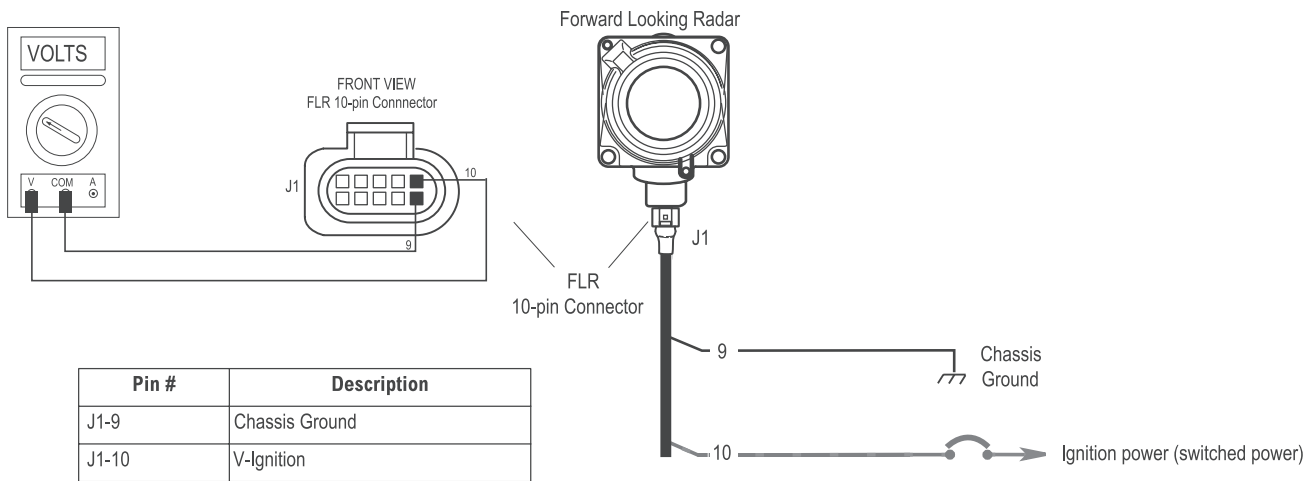

Step	Procedure
C	<ol style="list-style-type: none"> 1. Vehicle Ignition: Key-OFF, Engine-OFF. 2. Disconnect the 10-way connector from the VS-400 Forward Looking Radar (FLR). 3. Measure for zero voltage on pins 10 and 9 on the harness connector. <ol style="list-style-type: none"> a. If the voltage is 0.5 volts or less. <ol style="list-style-type: none"> i. Proceed to Step D. b. If voltage is greater than 0.5 volts but less than battery voltage. <ol style="list-style-type: none"> i. Test Failed. Check FLR power supply wiring for sources of stray voltage or shorts to voltage. c. If the voltage is within 0.6 volts of the battery voltage measured in Step A. <ol style="list-style-type: none"> i. Test Failed. The FLR is improperly wired or shorted to a battery power source. Correct the wiring by connecting the FLR to main ignition power supply bus and repeat Step.



Step	Procedure
D	<ol style="list-style-type: none"> 1. Vehicle Ignition: Key-ON, Engine-OFF. 2. Measure for ignition voltage on pins 10 and 9 on the harness connector. <ol style="list-style-type: none"> a. If the voltage is within 0.6 volts of the battery voltage measured in Step A. <ol style="list-style-type: none"> i. Proceed to Step E. b. If voltage is less than 0.6 volts of the battery voltage measured in Step A or open. <ol style="list-style-type: none"> i. Test Failed. Check component fuse. Troubleshoot power supply to the FLR for open / corroded connections or shorts to ground and repeat Step.

Verifying Component Power Up Timing

Verify the DIU and FLR are wired to the same ignition source. If either component is wired to a secondary ignition source with a delay, one of the components may set a Diagnostic Trouble Code (DTC) as a result of the other(s) delayed power cycle.

Step	Procedure
E	<ol style="list-style-type: none"> 1. Key-OFF. Let the truck sit for two minutes to allow time for the ECU's to completely power down. 2. Disconnect the 10-way connector from the back of the FLR and add a test lamp to ignition power pin 10. If the test lamp requires a ground pin, use pin 9 or chassis ground. <div style="text-align: center; margin: 10px 0;">  CAUTION </div> <p>Be careful not to spread pins on the FLR harness connector while performing this test.</p> 3. Disconnect the 8-way connector from the back of the DIU and add a test lamp to power pin 4. If the test lamp requires a ground pin, use pin 5 or ground the lamp to chassis ground. <div style="text-align: center; margin: 10px 0;">  CAUTION </div> <p>Be careful not to spread pins on the DIU harness connector while performing this test.</p> 4. While viewing both test lamps, turn the ignition key on to verify that both lamps light at the same time. <ol style="list-style-type: none"> a. If there is a noticeable delay before one lamp lights, the power source for the delayed light could be a secondary delayed ignition supply. <ol style="list-style-type: none"> i. Correct the wiring by connecting the appropriate component to the main ignition power supply bus. b. If the lamps light simultaneously. <ol style="list-style-type: none"> i. Test Passed. 5. Test Complete.

5. Wiring Diagrams

Collision Warning System with Side Object Detection

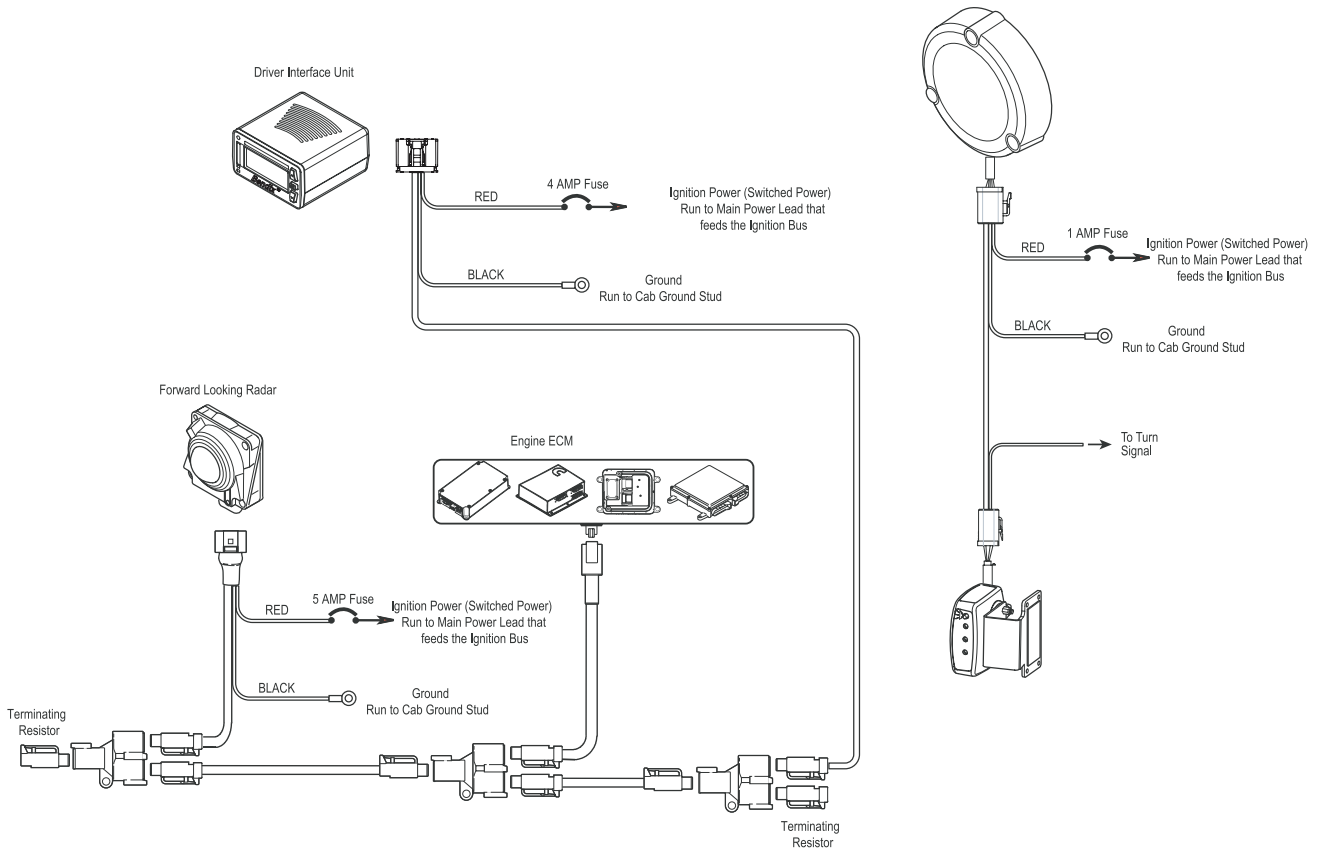

6. Connector Pin Descriptions

A. Forward Looking Radar

10-pin TRW Connector

PIN #	SIGNAL NAME	TYPE	INTERFACE LEVEL
1	NO_CONNECTION	-	-
2	NO_CONNECTION	-	-
3	J1939_SHIELD		TRUCK J1939 LINK
4	CAN_HI	-	TRUCK J1939 LINK
5	CAN_LO	-	TRUCK J1939 LINK
6	NO_CONNECTION	-	-
7	NO_CONNECTION	-	-
8	NO_CONNECTION	-	-
9	GROUND	POWER	CHASSIS GROUND
10	IGNITION	POWER	+12V SWITCHED



2 4 6 8 10

1 3 5 7 9

FRONT VIEW
FLR 10-pin Connector

B. Driver Interface Unit

8-Pin Molex Connector

PIN #	SIGNAL NAME	TYPE	INTERFACE LEVEL
1	RIGHT_SPEAKER	O	SPEAKER DRIVER 4 OHM / 1 WATT
2	LEFT_SPEAKER	O	SPEAKER DRIVER 4 OHM / 1 WATT
3	BLACKOUT_INPUT / SPARE	I	TRI-STATE INPUT
4	IGNITION	POWER	+9-32 VDC SWITCHED
5	GROUND	POWER	CHASSIS GROUND
6	CAN_LO		TRUCK J1939 LINK
7	CAN_HI		TRUCK J1939 LINK
8	SPARE_ANALOG	I	TRI-STATE INPUT



1 2 3 4

5 6 7 8

C. Side Sensor Display Unit

4-pin Deutsch Connector

PIN #	SIGNAL NAME	TYPE	INTERFACE LEVEL
1	POWER	I	+12V FROM SENSOR
2	GROUND	POWER	CHASSIS GROUND
3	COMMUNICATION	I	
4	TURN_SIGNAL	I	+12V

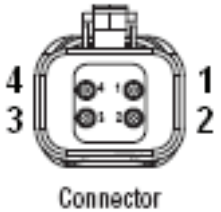

Connector

D. Side Sensor

6-pin Deutsch Connector

PIN #	SIGNAL NAME	TYPE	INTERFACE LEVEL
1	IGNITION	POWER	+12V SWITCHED
2	GROUND	POWER	CHASSIS GROUND
3	COMMUNICATION	O	
4	POWER	O	+12V
5	SODDU-GROUND	POWER	GROUND
6	NO CONNECTION	-	-



Connector

7. Extracting Bendix™ VORAD® system Data

A. Data Availability

Data will not be stored by the system until the proper Bendix® ACom® Diagnostics license key is present and the "Clear Resettable Data Log" option is selected. See diagram 1 (right). Contact Bendix (1-800-AIR-BRAKE) for the ACom Diagnostics license key and its set-up procedure.

B. Data Overview

At the fleet's discretion, Bendix™ VORAD® makes a data log available. The log can be reset using the Bendix ACom Diagnostics software as often as needed.

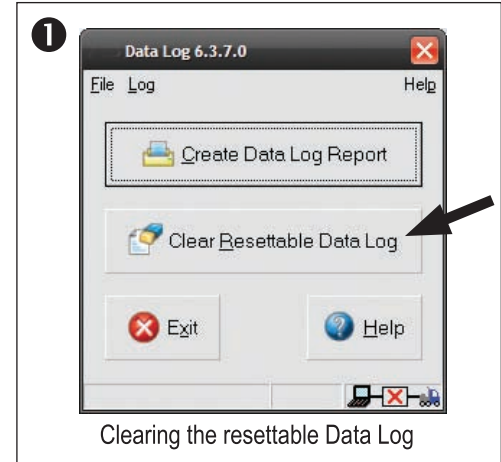

INITIALIZING DATA

1. Bendix ACom Diagnostics 6.4 or higher is required for this procedure. The ACom Diagnostics software and its User Guide are available online at "Diagnostic Software" link under "Services and Support" on the Bendix website (www.bendix.com).
2. Obtain the Bendix VORAD "Data Extraction" license key from Bendix by calling the Tech Team at 1-800-AIR-BRAKE (1-800-247-2725).
3. After the diagnostics tool has been successfully connected to the vehicle, the service technician will be presented with the window shown to the right. See Diagram 2.
4. Select "VORAD Data Log", then select "Start Data Log".
5. Select "Clear Resettable Data Log".
6. Select "No" when asked if you want to save the Log.
7. Select "OK" to exit.

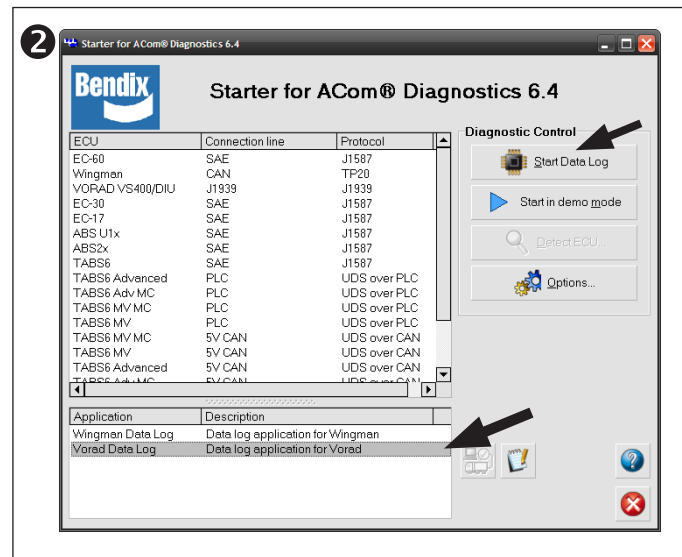

EXTRACTING DATA AND SAVING A REPORT

(Only available after the above "Initializing Data" procedure has been followed and the vehicle has been driven for more than 20 miles.)

1. Bendix ACom Diagnostics 6.4 or higher is required for this procedure.
2. After the diagnostics tool has been successfully connected to the vehicle, the service technician will be presented with the window shown to the right. See Diagram 2.
3. Select "VORAD Data Log", then select "Start Data Log". See Diagram 2.
4. Select "Create Data Log Report". See diagram 1.
5. Enter the vehicle data (mileage, ID), select "Continue". See diagram 3.
6. Select the type of report you require ("Print", "Print Preview", "E-mail", or "Save"), then select "OK". See diagram 4.
7. After saving the report, if you wish to reset the log, select "yes".

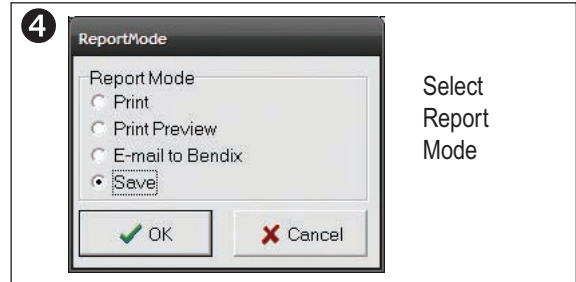
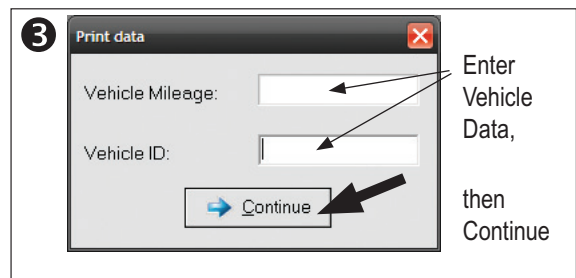

See the next page for a sample report.



Vorad VS-400 Data
 ACom-Diagnostics v6.5.8.0
 ACom - Vorad Log v2.0.3.0

Vehicle ID: Test

Vehicle Mileage: 0

901 Cleveland Street
 Elyria, OH 44035
 800-AIR-BRAKE
 www.bendix.com

DATA LOG

Following Time Histogram (seconds)	ACC		Net ACC		Total	
	Hours	%	Hours	%	Hours	%
0 - 0.5	0.00	0.00	0.00	0.00	0.00	0.00
0.5 - 1.0	0.00	0.00	0.00	0.00	0.00	0.00
1.0 - 1.5	0.00	0.00	0.00	0.00	0.00	0.00
1.5 - 2.0	0.00	0.00	0.00	0.00	0.00	0.00
2.0 - 2.5	0.00	0.00	0.00	0.00	0.00	0.00
2.5 - 3.0	0.00	0.00	0.00	0.00	0.00	0.00
3.0 - 3.5	0.00	0.00	0.00	0.00	0.00	0.00
3.5 - 4.0	0.00	0.00	0.00	0.00	0.00	0.00
4.0 - 4.5	0.00	0.00	0.00	0.00	0.00	0.00
4.5 - 5.0	0.00	0.00	0.00	0.00	0.00	0.00
5.0 & up	0.00	0.00	0.00	0.00	0.00	0.00
Total	0.01	0.02	0.02	0.02	0.02	100.00

Following Distance Histogram	Hours		Total		Avg MPH
	Hours	%	Hours	%	
0' - 25'	0.00	0.00	0.00	0.00	0.00
25' - 50'	0.00	0.00	0.00	0.00	12.83
50' - 75'	0.00	0.00	0.00	0.00	14.35
75' - 100'	0.00	0.00	0.00	0.00	16.61
100' - 150'	0.01	0.01	0.01	0.01	25.53
150' - 200'	0.00	0.00	0.00	0.00	33.62
200' - 250'	0.01	0.01	0.01	0.01	49.27
250' - 300'	0.00	0.00	0.00	0.00	37.43
300' - 400'	0.00	0.00	0.00	0.00	43.75
400' - up	0.00	0.00	0.00	0.00	0.00
Total	0.02	0.02	0.02	0.02	0.00

Usage data		Trip Time		%		Avg. Speed	
Item	Value	Hours	%	Hours	%	Hours	Avg. Speed
Time w/ forward vehicle present	24%	0.03	79	0.10	79	0.10	24.31
0.5g Brake events	0.00	0.00	21	0.03	21	0.03	
ACC Engine Brake Events	1.00	0.13		0.13		0.13	
System On	17%	3.18		3.18		3.18	
Coasting events	0.00						
Avg Coasting Time (seconds)	0.00						
Collision Alerts	0.00						

Idle Time		%		Hours	
Item	Value	Hours	%	Hours	%
Idle Time	58	0.07	50	0.07	50
Fast Idle Time	0.08	0.08	58	0.08	58
Total Idle Time	0.14	0.14	108	0.14	108

Trip Reset Date		Dates	
Item	Value	Item	Value
Trip Reset Date	6/21/2012	Trip Extracted Date	6/25/2012

Typical VORAD vehicle report

Vendor Contact Information

AMP/Tyco

Harrisburg, PA
Tel: 800.522.6752
<http://www.tycoelectronics.com/>

Champlain Cable Corporation

175 Hercules Drive
Colchester, Vermont 05446
Tel: 800.451.5162
<http://www.champcable.com/>

Deutsch

LADD Industries
4849 Hempstead Station Dr.
Kettering, OH 45429
Tel: 800.223.1236
<http://www.laddinc.com>

FEP

FAHRZEUGELEKTRIK PIRNA GmbH & CO. KG
Hugo-Küttner-Straße 8
01796 Pirna
Tel: +49 3501 514 0
http://www.fepz.de/en/e_index.html

Littelfuse World Headquarters

800 E. Northwest Highway
Des Plaines, IL 60016
Tel: 847.824.1188
Fax: 847.391.0894
<http://www.littelfuse.com>

Molex

2222 Wellington Court
Lisle, IL 60532-1682
Tel: 800.78MOLEX
<http://www.molex.com>

Packard

Delphi Connection Systems
5725 Delphi Drive
Mail Station 483.400.301
Troy, MI 48098
Tel: 800.610.4835
<http://www.delphisecure2.com/site/home/homemain.asp>

Packard Distributor

Power & Signal Group
World Headquarters
4670 Richmond Road
Suite 120
Cleveland, OH 44128
Tel: 800.722.5273 or 216.378.6600
<http://www.powerandsignal.com>

