

Stainless Steel Accessories

GRILLE SURROUND

INSTALLATION INSTRUCTIONS

1. Unbolt the grille from the truck
2. Center the bottom piece of the grille surround on the truck and tape in place.
3. Place the side sections in the desired location overtop the bottom piece, making sure that the holes in the bottom of the sides line up with the end mounting holes of the bottom piece. Tape in place.
4. Place the bug deflector overtop the side sections and line up the holes. Tape in place as well.
5. Using a pen, transfer all the mounting hole locations to the truck and set the panels aside.
6. Drill each location marked to 5/16".
7. Place a #10-32 nutsert into each location drilled, excepting the locations where the sides will be bolted to the bottom piece and bug deflector. Install the supplied #10-32 toothed lockwasher and #10-32 x 3/4" socket head cap screw (through the 7/32" hole in supplied flat-plate), into a nutsert and tighten. This will expand the nutsert and fix it in place. Repeat for each nutsert. (see diagram below)
8. Re-install the components to the truck with the supplied #10-32 x 1/2" truss head screws.
9. Attach the bug deflector and bottom piece to the sides using the supplied #10-32 x 1/2" nuts, bolts and washers and tighten.
10. Remove plastic coating and clean with glass cleaner if necessary
11. Re – install grille.

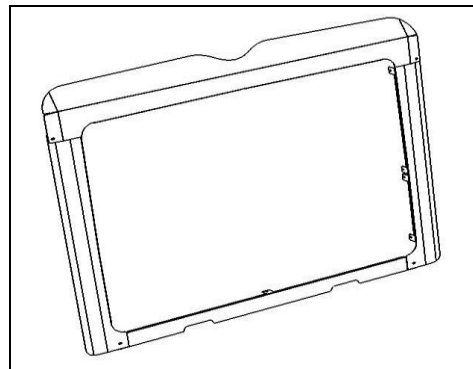
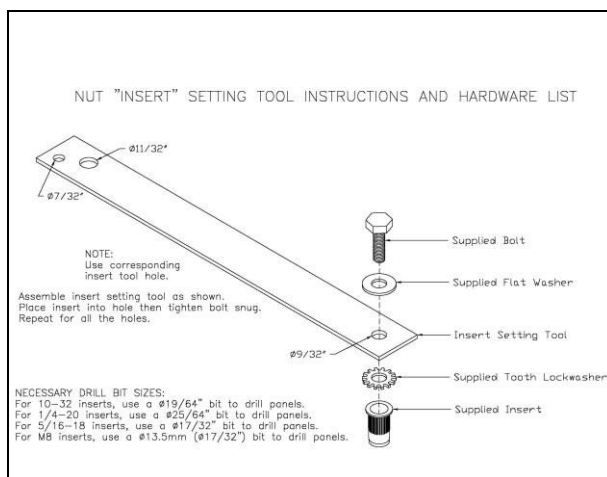

NUT "INSERT" SETTING TOOL INSTRUCTIONS AND HARDWARE LIST

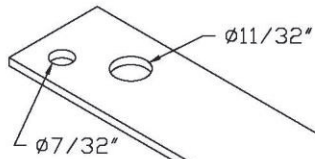

NOTE:
Use corresponding
insert tool hole.

Assemble insert setting tool as shown.
Place insert into hole then tighten bolt snug.
Repeat for all the holes.

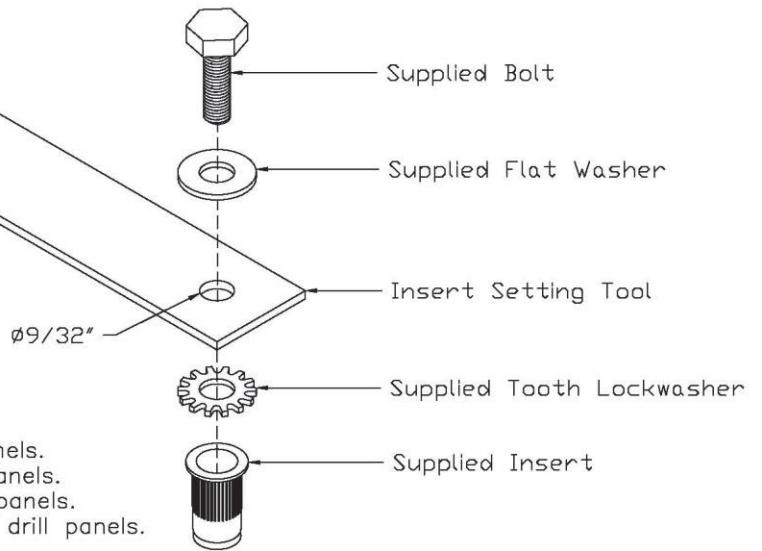

NECESSARY DRILL BIT SIZES:

For 10-32 inserts, use a $\phi 19/64''$ bit to drill panels.
For 1/4-20 inserts, use a $\phi 25/64''$ bit to drill panels.
For 5/16-18 inserts, use a $\phi 17/32''$ bit to drill panels.
For M8 inserts, use a $\phi 13.5\text{mm}$ ($\phi 17/32''$) bit to drill panels.