

This Service Bulletin replaces SB 451-23, "Drive Shaft Installation, Driveline Phasing, VOLVO, Meritor, Eaton Axles, VN, VHD VERSION2" (11.02), publication no. PV776-TSP182393.

Date	Group	No.	Page
8.2007	<b>451</b>	<b>23</b>	1(3)

Drive Shaft Installation  
Driveline Phasing  
VOLVO, Meritor, Eaton Axles  
VN, VHD VERSION 2

## Drive Shaft Phase Angles

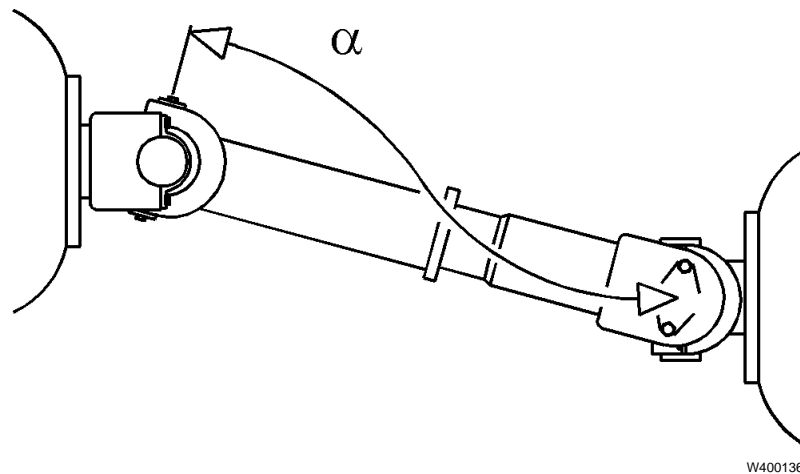

Drive shafts are designed to have a particular phase angle. The following information is intended to be used as a general guideline for phase angle specifications for proper driveline installation. In some cases, the factory-installed drive shafts were phased differently than listed in this information. If there is a question, call technical support to check the truck build record for special phasing.

### Contents

- "Drive Shaft Phase Angles" page 2
  - "Center Bearing Shaft Phase Angle" page 2
  - "Main Shaft Phase Angle" page 2
  - "Interaxle Drive Shaft Phase Angle" page 3

**Note:** Information is subject to change without notice. Illustrations are used for reference only and may differ slightly from the actual vehicle being serviced. However, key components addressed in this information are represented as accurately as possible.

## Drive Shaft Phase Angles

### Center Bearing Shaft Phase Angle

Truck Model	Axle Model	$\alpha$ - Center Bearing Shaft Phase Angle
VN Series	All	90°
VHD Series	All	90°

### Main Shaft Phase Angle

Truck Model	Axle Model	$\alpha$ - Main Shaft Phase Angle
VN Series	All	0° to first drive axle
VHD Series	All	0° to first drive axle

## Interaxle Drive Shaft Phase Angle

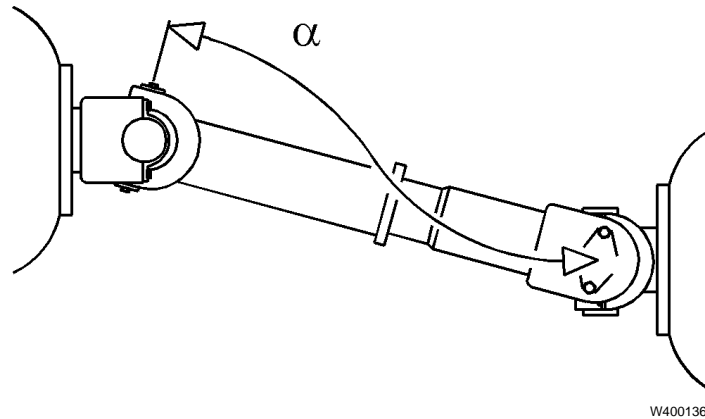

The interaxle drive shafts are designed to have a particular phase angle as shown in the following table (table page 3). If the shaft is phased correctly it should not be changed.

If the shaft is not phased correctly, it should be properly phased and rebalanced. It is very important to have the balancing operation done before reinstalling the newly phased shaft, to eliminate vibration and wear problems associated with the shaft.

Truck Model	Axle Model	$\alpha$ - Interaxle Shaft Phase Angle
VN/VHD Series	Volvo	116.5° (11 Spline Teeth)
VN/VHD Series	Eaton D462/463	116.5° (11 Spline Teeth, 52- to 60-in. spread) 137.6° (13 Spline Teeth, 72-in. spread)
VN/VHD Series	Eaton D404	137.6° (13 Spline Teeth)
VN/VHD Series	Meritor	0°

The proper way to check the phasing is as follows:

- 1 Looking down the length of the shaft, hold the end yoke farthest away vertical and still.
- 2 Turn the end yoke, closest to you, counterclockwise to the proper angle or the proper number of spline teeth.

**Note:** If the shaft is phased, there are “timing” marks near the splines.

**Note:** Trucks with certain Eaton axles that previously had 0° interaxle shaft phasing will now be phased. Any phasing change done to trucks already in service will require the shaft to be rebalanced.